

CHM[®]



















CHARFIX^{system 2}







INTRAMEDULLARY OSTEOSYNTHESIS OF HUMERUS

- *IMPLANTS*
- *INSTRUMENT SET 40.5880.600*
- *SURGICAL TECHNIQUE*



SYMBOLS DESCRIPTIONS

	Titanium or titanium alloy		H length [mm]
	Cobalt		Angle
	Left		available lengths
	Right		Available number of holes
	Available versions: left/right		Thickness [mm]
	Length		Scale 1:1
	Torx drive		Number of threaded holes in the shaft part of the plate
	Torx drive cannulated		Number of locking holes in the plate
	Hexagonal drive		Variable angle
	Hexagonal drive cannulated		Cortical
	Cannulated		Cancellous
	Locking		Available in sterile/ non- sterile condition
	Diameter [mm]		Refer to surgical technique

	Caution - pay attention to the particular proceeding.
	Perform the activity with X-Ray control.
	Information about the next stages of the proceeding.
	Proceed to the next stage.
	Return to the specified stage and repeat the activity.
	Before using the product, carefully read the Instructions for Use supplied with the product. It contains, among others, indications, contraindications, side effects, recommendations and warnings related to the use of the product.
	The above description is not a detailed instruction of conduct. The surgeon decides about choosing the operating procedure.

www.chm.eu

Document No ST/43B-2
 Date of issue 25.07.2014
 Review date P-013-21.02.2020

The manufacturer reserves the right to introduce design changes.
 Updated INSTRUCTIONS FOR USE are available at the following website: www.chm.eu

I. INTRODUCTION	5
II. IMPLANTS	8
II.1. SHORT NAIL	8
II.2. LONG NAIL	9
II.3. LOCKING ELEMENTS	10
III. INSTRUMENT SET	11
IV. SURGICAL TECHNIQUE	14
IV.1. SURGERY PLANNING	14
IV.2. PROXIMAL INSERTION OF THE HUMERAL NAIL	14
IV.3. DISTAL HUMERAL NAIL INSERTION	41
IV.4. TARGETER - NAIL DISASSEMBLY	55
IV.5. INSERTION OF THE COMPRESSION SCREW OR END CAP	56
IV.6. NAIL EXTRACTION	57

I. INTRODUCTION

CHARFIX^{system 2}

- INTRAMEDULLARY OSTEOSYNTHESIS OF HUMERUS, consists of:

- implants (*intramedullary nail, locking screws, end cap or compression screw*),
- instrument set for implantation and extraction after finished treatment,
- surgical technique.

The presented range of implants is made of titanium and its alloys and implantable steel in accordance with ISO 5832 standards.

Intramedullary osteosynthesis of humeral bone provides stable fixation of fractured humeral shaft and is recommended in the following cases:

- multi-fragmental shaft fractures,
- severe closed or open (*I grade*) fractures,
- pathological fractures, malunion or nonunion of shaft fractures previously treated with other methods.

Humeral nail is available in:

- diameter: 6-12mm (*in 1mm increments*),
- length size: 180-320mm (*for long nail*), 150 - 200 (*for short nail*),
- solid or cannulated version,
- titanium alloy.







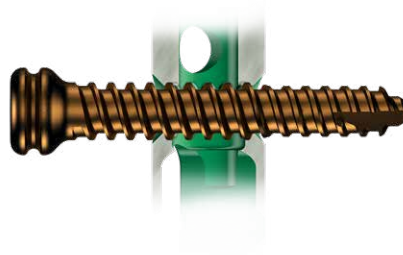
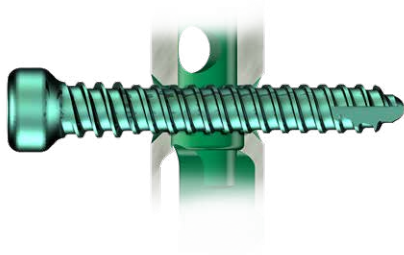





Nail design enables implantation into both right and left limb. There are 6 holes in the proximal part that allow for fixation of damaged fragments of humeral head. Threaded locking holes in the proximal part allow for optional locking using:

- CHARFIX2 locking screw 3.0 or 4.0;

- CHARFIX2 locking screw 4.5, which by anchoring in the nail prevents angle displacement and movement of fracture fragments



Diameter of intramedullary nail

		Ø6 and Ø7 mm		Ø8 mm and larger	
		Standard locking	Standard locking with angular stabilization	Standard locking	Standard locking with angular stabilization
Proximal part	Round Hole 	CHARFIX2 Distal screw 4.0 <i>(turquoise)</i> 	CHARFIX2 Distal screw 4.5 <i>(brown)</i> 	CHARFIX2 Distal screw 4.0 <i>(turquoise)</i> 	CHARFIX2 Distal screw 4.5 <i>(brown)</i> 
	Oval Hole 	CHARFIX2 Distal screw 4.0 <i>(turquoise)</i> 		CHARFIX2 Distal screw 4.0 <i>(turquoise)</i> 	
Distal part	Round Hole 	CHARFIX2 Distal screw 3.0 <i>(pink)</i> 		CHARFIX2 Distal screw 4.0 <i>(turquoise)</i> 	CHARFIX2 Distal screw 4.5 <i>(brown)</i> 

CHARFIX system 2 provides the surgeon with the following stabilization methods, depending on the fracture type.

Static method

Static fixation is used to eliminate or limit movements in bone-nail-screws structure. Implant design allows for multidimensional locking in 4 distal holes and in 5 round holes and one oval in the proximal part.



Dynamic method with compression

In dynamic fixation with compression the compression screw shall be axially inserted into the nail shaft in order to put pressure on locking screw. The fixation with compression eliminates all micro-movements in the initial stage of fracture treatment.



Retrograde insertion of the nail

Humeral bone fractures located in the shaft, epiphysis and metaphysis of the proximal humerus may also be fixed by using nail inserted from distal epiphysis of humerus.



CHARFIX2 HUMERAL NAIL

CHARFIX *system 2*

II. IMPLANTS

II.1. SHORT NAIL

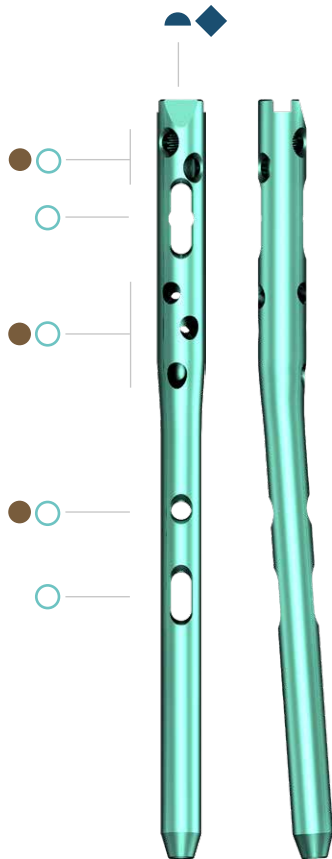
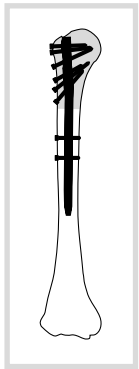

Len			Ti
150	8	3.2978.150	
	9	3.2979.150	
available		Ø	6 mm +10 mm
		L	150 mm + 200 mm
		pitch	1mm 5 mm



	Ti					
	3.5170.xxx	✓	✓	4.5	25÷70	
	3.5169.xxx	✓		4.0	25÷70	
	3.5162.004	✓				
	3.5161.2xx	✓	✓			

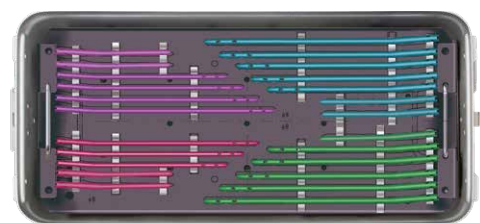

Stand for humeral nails (implants not included)

40.5751.000

CHARFIX2 HUMERAL NAIL



II.2. LONG NAIL

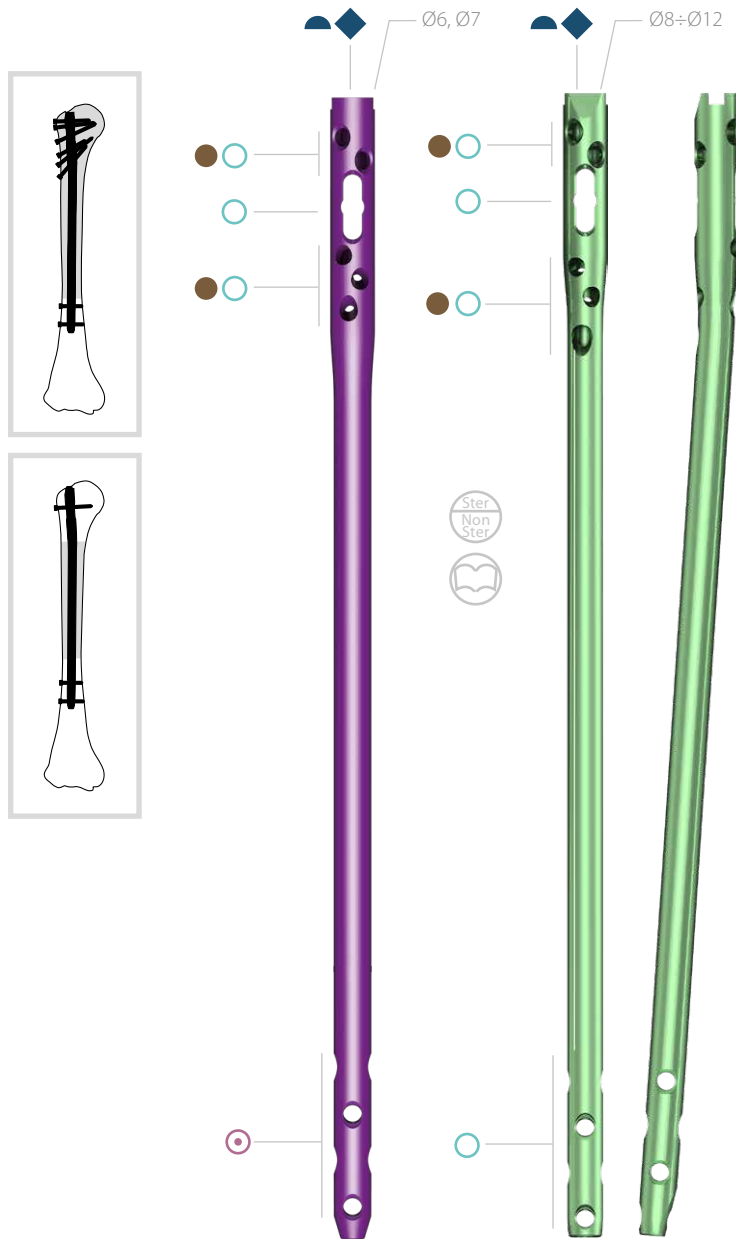

	Len	Ti
6	180	3.2956.180
	200	3.2956.200
	220	3.2956.220
	240	3.2956.240
	260	3.2956.260
	280	3.2956.280
7	300	3.2956.300
	320	3.2956.320
	180	3.2957.180
	200	3.2957.200
	220	3.2957.220
	240	3.2957.240
8	260	3.2957.260
	280	3.2957.280
	300	3.2957.300
	320	3.2957.320
	180	3.2958.180
	200	3.2958.200
9	220	3.2958.220
	240	3.2958.240
	260	3.2958.260
	280	3.2958.280
	300	3.2958.300
	320	3.2958.320
available	Ø	6 mm ±12 mm
	L	180 mm ± 320 mm
	pitch	1 mm
		5 mm

	Ti					
	3.5170.xxx	✓	✓	4.5	25÷70	
	3.5169.xxx	✓		4.0	25÷70	
	3.5173.xxx	✓		3.0	20÷50	
	3.5162.004	✓				
	3.5161.2xx	✓	✓			

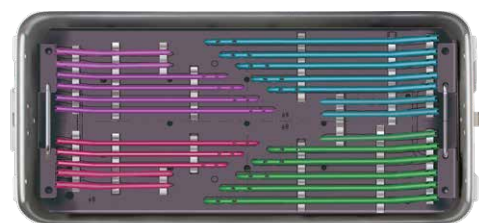

Stand for humeral nails (implants not included)

40.5751.000

II.3. LOCKING ELEMENTS

LOCKING ELEMENTS



CHARFIX2 DISTAL SCREW 4.0



25	3.5169.025
30	3.5169.030
35	3.5169.035
40	3.5169.040
45	3.5169.045
50	3.5169.050
55	3.5169.055
60	3.5169.060
65	3.5169.065
70	3.5169.070



CHARFIX2 DISTAL SCREW 4.5



25	3.5170.025
30	3.5170.030
35	3.5170.035
40	3.5170.040
45	3.5170.045
50	3.5170.050
55	3.5170.055
60	3.5170.060
65	3.5170.065
70	3.5170.070



CHARFIX2 DISTAL SCREW 3.0



20	3.5173.020
25	3.5173.025
30	3.5173.030
35	3.5173.035
40	3.5173.040
45	3.5173.045
50	3.5173.050



CHARFIX2 COMPRESSION SCREW M6X1



3.5162.004

CHARFIX2 END CAP M6

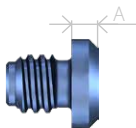

A	
0	3.5161.200
+2.5	3.5161.202
+5	3.5161.205













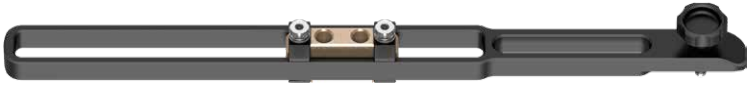

























Stand for CHARFIX2 nail locking elements (set with a box without implants)



40.5058.200

III. INSTRUMENT SET

The fixation of the humeral shaft fractures, and implants removal after finished treatment shall be carried out with the instrument set [40.5880.600].

40.5880.600	Name	Pcs	Catalogue No.
	Targeter arm	1	40.5881.000
	Proximal targeter	1	40.5882.100
	Distal targeter	1	40.5883.100
	Connecting screw M6x1 spec. L-62	1	40.5884.000
	Compression screw	1	40.5887.000
	Connector M6/M14	1	40.5888.000
	Screwdriver T25	1	40.5575.400
	Trocar 6.5	1	40.5534.100
	Set block 9/4.0/3.0	2	40.5890.100
	Protective guide 9/7	2	40.5510.200
	Drill guide 7/3.5	2	40.5511.200
	Protective guide 18/7.0	1	40.5035.100
	Humeral gauge	1	40.5891.000
	Drill with scale 3.5/150	1	40.5343.002
	Drill with scale 2.5/150	1	40.5344.002
	Drill with scale 3.5/350	2	40.5339.002
	Drill with scale 2.5/320	2	40.5342.002
	Impactor-extractor	1	40.5308.000
	Wrench S8	1	40.5304.000
	Screw length measure	1	40.5530.100

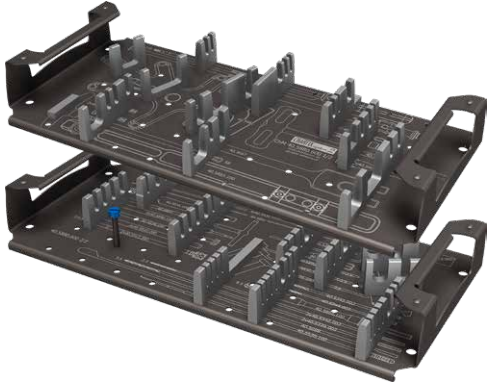
40.5880.600	Name	Pcs	Catalogue No.
	Guide rod 2.5/580	1	40.3673.580
	Guide rod handle	1	40.1351.000
	Teflon pipe guide 7/290	1	40.3699.000
	Aiming insert 9.0	2	40.5065.009
	Curved awl 8.0	1	40.5523.000
	Nail length measure	1	40.5098.000
	Mallet	1	40.3667.000
	Protective guide short	1	40.5871.100
	Drill guide short	1	40.5872.100
	Drill guide short 7/2.5	1	40.5892.100
	Trocar short 7	1	40.1354.100
		1	40.5315.100
	Cannulated drill 9.5/3.0	1	40.5885.100
	Protective guide 12.5/4	1	40.5886.100
	Guide rod 2.8/385	4	40.5531.000
	Cutter 7.0	1	40.5897.000

40.5880.600	Name	Pcs	Catalogue No.
	Perforated aluminum cover 1/1 595x275x15mm gray	1	12.0750.200
	Stand for instrument set of humeral nails	1	40.5899.600
	Container with solid bottom 1/1 595x275x135mm	1	12.0750.103

To carry out the surgery, some necessary basic devices are needed:

- electric drive,
- set of flexible intramedullary reamers of diameter: 6.0 - 11.0 mm with guide and handle,
- and other devices.

IV. SURGICAL TECHNIQUE



The following description covers the most important stages of the implantation of the humeral intramedullary nails; however, it is not a detailed instruction of conduct. The surgeon decides about choosing the operating procedure and its application in each individual case.

IV.1. SURGERY PLANNING

X-Ray of humeral fracture in AP and lateral position shall be performed before starting the operation in order to define the humeral shaft fracture type and to choose the proper nail size (*length, diameter*).

If required, X-Ray of the opposite healthy humerus shall be performed.

The operation shall be performed on the operating table equipped with X-Ray device and visual track. Patient shall be placed supine or on the healthy side (*depends on surgeon's preference*), on the edge of the radiolucent table.

The intramedullary nail can be inserted into medullary canal as follows:

- proximally (*from humeral joint side*),
- distally (*from distal part of bone shaft*).

The proximal surgical approach of intramedullary nail shall be prepared by:

- 2-3 cm skin incision, starting from clavicle-shoulder joint in anterior-lateral direction but parallel to deltoid muscle fibers,
- splitting fibers of deltoid muscle,
- exposing supraspinous muscle attachment and its slight splitting.

IV.2. PROXIMAL INSERTION OF THE HUMERAL NAIL

IV.2.1. OPENING OF THE MEDULLARY CANAL

1 After preparing the surgical approach, in order to open the medullary canal, use the electric drive to insert the guide rod 2.8/385 **[40.5531]** slightly medially to the greater tubercle in the axis of medullary canal.



This step should be performed under image intensifier control.

Guide rod **[40.5531]** acts as a guide for the cannulated awl or drill.



Guide rod 2.8/385 **[40.5531]** is a single use instrument.



40.5531.000

2a Insert protective guide [40.5315.100] with protective guide 12.5/4 [40.5886.100] via the guide rod 2.8/385 [40.5531], until the cortical bone is reached.
 Remove protective guide 12.5/4.
 Open the medullary canal guiding the cannulated drill 9.5/3.0 [40.5885.100] via the guide rod.

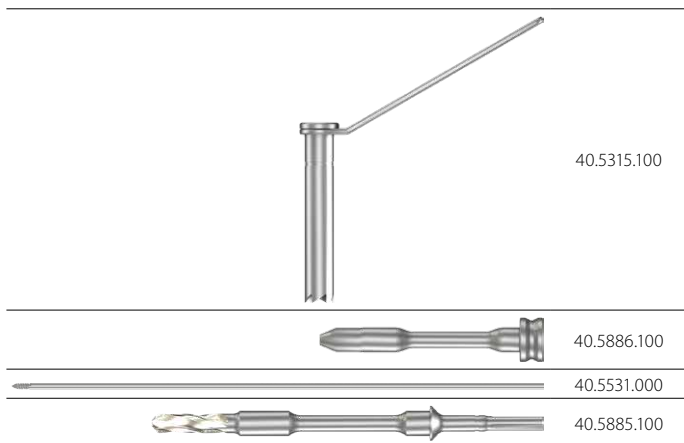

2b It is also possible to open the medullary canal using the curved awl 8.0[40.5523], guiding it via guide rod for the depth of approx. 7 cm.

Remove the awl and the guide rod.



It is recommended to open the medullary canal with technique described in steps 1 and 2. The chosen surgical technique depends on surgeon's preference and available equipment in the operation suite.

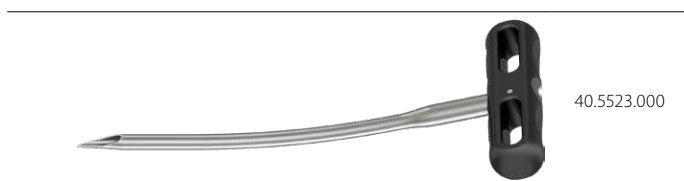

IV.2.2. PREPARATION OF THE MEDULLARY CANAL

Reamed canal

3 Insert the guide rod 2.5/580 [40.3673.580] into the medullary canal to the appropriate depth, reducing the fracture at the same time. Gradually widen the medullary canal using flexible reamers with 0.5mm increments, until reaching the diameter which is 0.5mm wider than the diameter of the humeral nail, for the depth not lesser than the nail length. The proximal part of the medullary canal should be reamed to the diameter of 11mm, to the depth of approx. 7cm. (proximal part of the nail is wider than its distal part).

Remove the flexible reamer.
Leave the guide rod [40.3673.580] in the medullary canal.

When using a different guide (guide rod) for the reamer than the guide rod 2.5/580 included in the instrument set, the guide should be replaced with the guide rod 2.5/580 [40.3673.580] for measuring the nail length. Having reamed the canal, using the flexible reamer guide, insert teflon pipe guide 7/290 [40.3699] into the medullary canal. Remove the reamer guide. Install guide rod 2.5/580 [40.3673.580] (cannulated nail guide) in the guide rod handle [40.1351] and then insert into teflon pipe guide 7/290 to the required depth. Remove the guide rod handle and teflon guide.

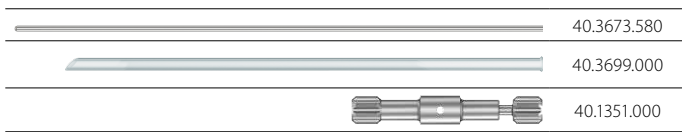

4 Place the nail length measure [40.5098] onto the guide rod 2.5/580 [40.3673.580] until it contacts the bone. The end of the guide rod indicates the implant length.

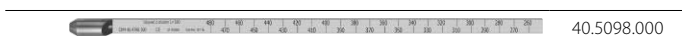

5 In the case of using solid nail, remove the guide rod 2.5/580 [40.3673.580] from the medullary canal using the guide rod handle [40.1351].

The medullary canal is prepared for the humeral nail insertion.

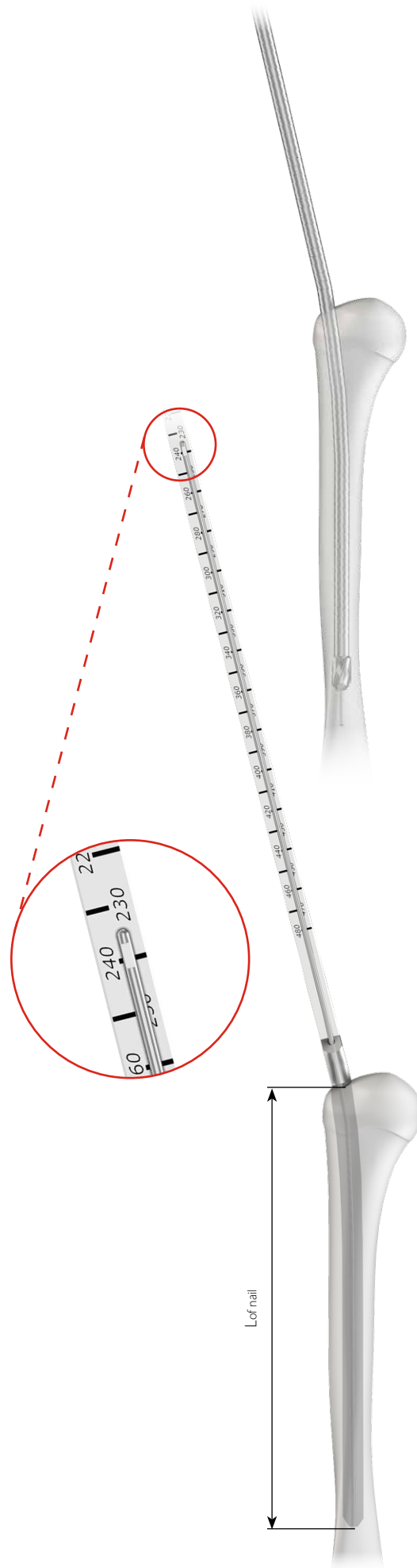
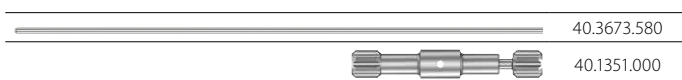

IV.2.3. TARGETER ARM AND NAIL ASSEMBLY. DISTAL TARGETER POSITIONING

- 6 Using the wrench S8 [40.5304] and the connecting screw M6x1 spec. L-62[40.5884], mount the intramedullary nail to the targeter arm [40.5881].
- 7 Mount the distal targeter [40.5883.100] onto the targeter arm [40.5881].
- 8 Using two set blocks 9/4.0/3.0 [40.5890.100], position the slider of the targeter with distal locking holes of intramedullary nail. Lock the slider of the targeter using the screwdriver [40.5575.400].



CHECK:
Properly set and secured slider enables set blocks to smoothly hit the nail holes.

Remove set blocks from slider of the targeter. Remove distal targeter.

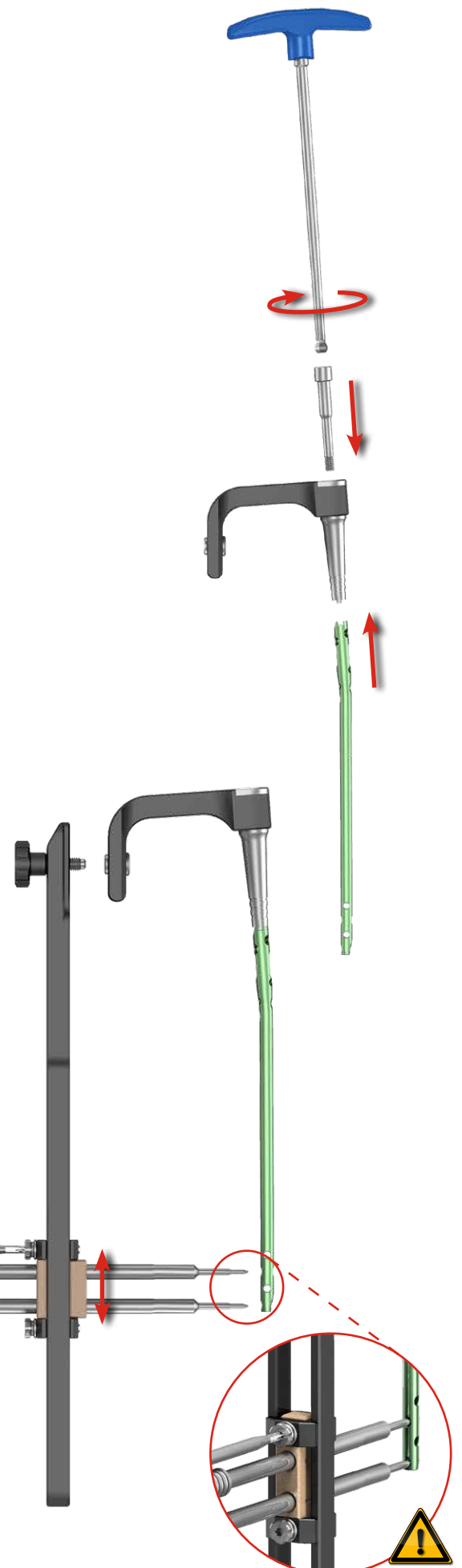

IV.2.4. NAIL INSERTION

- 9 Insert the humeral nail into the medullary canal until the desired depth is reached using the mallet [40.3667] and attached impactor-extractor [40.5308].



The cannulated nail shall be inserted into the humeral medullary canal via the guide rod 2.5/580 [40.3673.580]. The solid nail is inserted directly into the humeral medullary canal (without using the guide rod).

Remove impactor-extractor from the targeter arm.
Remove the guide rod (only if cannulated nail has been implanted).

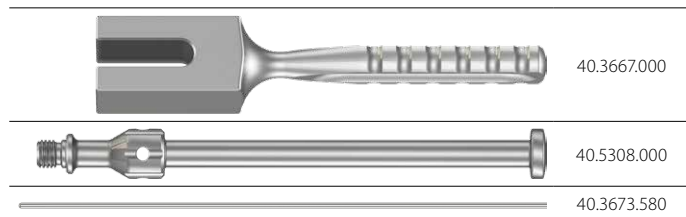

IV.2.5. DISTAL LOCKING OF THE NAIL

- 10** Attach distal targeter [40.5883.100] to the targeter arm [40.5881]. Before starting distal locking, verify with X-Ray device and the aiming inserts 9.0 [40.5065.009] the mutual position of holes of the slider of the distal targeter and distal holes of the intramedullary nail.

Holes in the nail and the slider have to be in line - the image on the screen has to be of a circle shape (an image similar to the circle is allowed).

Insert respectively the protective guide 9/7 [40.5510.200] and the trocar 6.5 [40.5534.100] into the proximal and then distal hole of the distal targeter slider [40.5883.100]. Mark on the skin the entry point for the locking screw insertion. Make 1.5 cm incision.

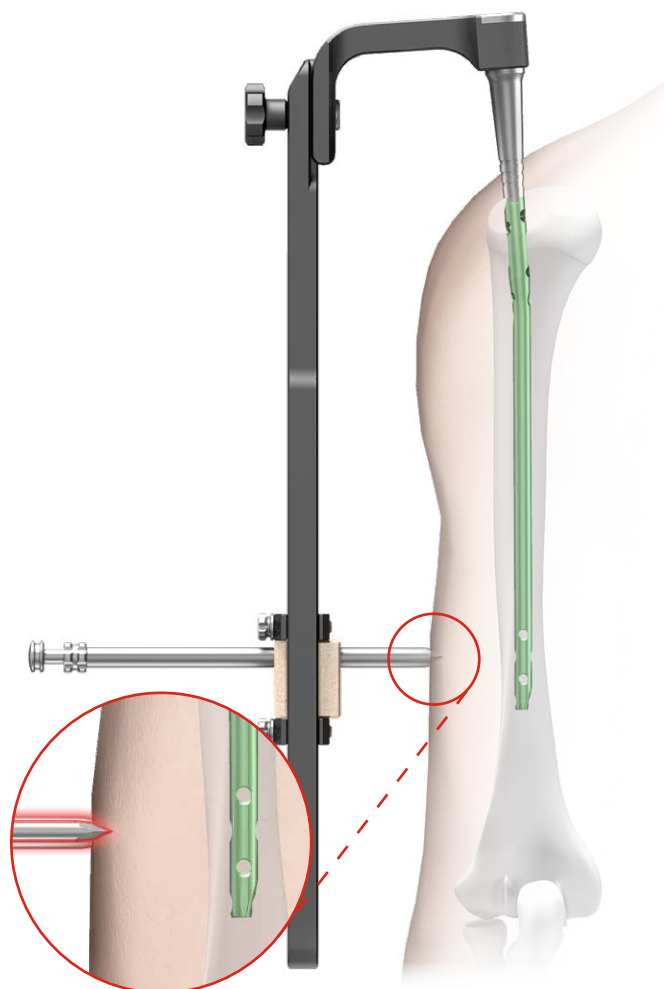
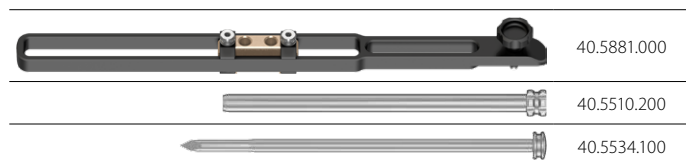

- 11** Insert protective guide 9/7 [40.5510.200] and trocar 6.5 [40.5534.100] into the slider hole of the distal targeter [40.5883.100]. Protective guide and trocar shall be inserted into the prepared incision until the end of the guide reaches cortical bone. Use the trocar to mark on the bone the entry point for the locking screw.

Remove the trocar.

Leave the protective guide in the slider hole.



12 Drill the hole in the humeral bone for locking screw insertion.



Option I

Implantation of 8÷10 mm nail (use 4.0/4.5 mm screws).

Insert the drill guide 7/3.5 [40.5511.200] into the protective guide 9/7 [40.5510.200]. Mount the drill with scale 3.5/350 [40.5339.002] to the surgical drive and advance such system through the drill guide 7/3.5 [40.5511.200]. Drill the hole in the humerus through both cortical layers under the X-Ray control. The scale on the drill indicates the length of the locking element.

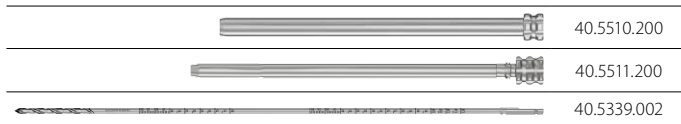

Option II

Implantation of 6 or 7mm nails (use 3.0 screws).

Insert the drill guide 7/3.5 [40.5511.200] into the protective guide 9/7 [40.5510.200]. Mount the drill with scale 2.5/320 [40.5342.002] to the surgical drive and advance such system through the drill guide 7/3.5 [40.5511.200]. Drill the hole in the humerus through both cortical layers under the X-Ray control. The scale on the drill indicates the length of the locking element.

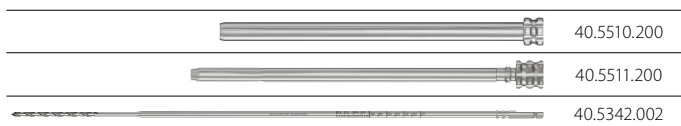

Disconnect the surgical drive and the drill. Leave in place the following system: protective guide – drill guide – drill.

	protective guide 9/7		drill guide 7/3.5		drill
Option I	[40.5510.200]	-	[40.5511.200]	-	[40.5339.002]
Option II	[40.5510.200]	-	[40.5511.200]	-	[40.5342.002]

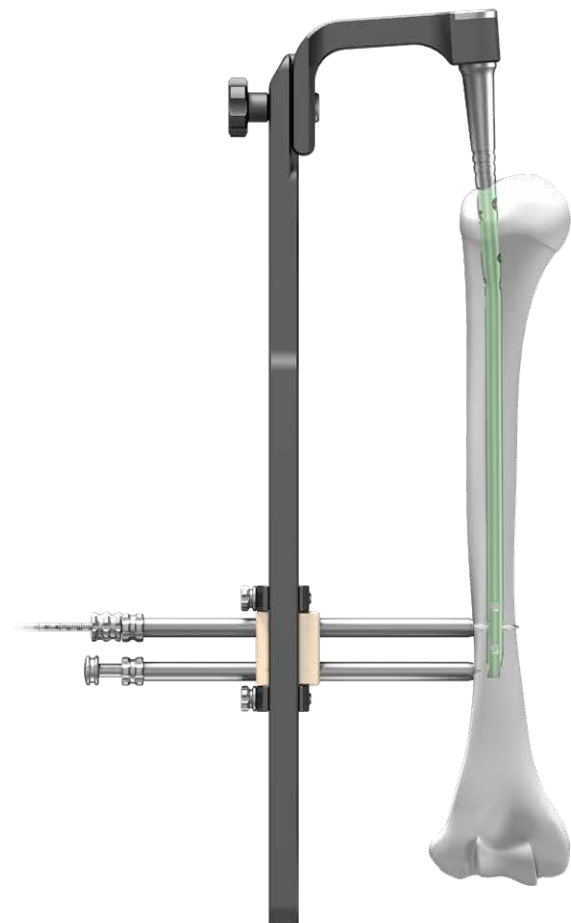
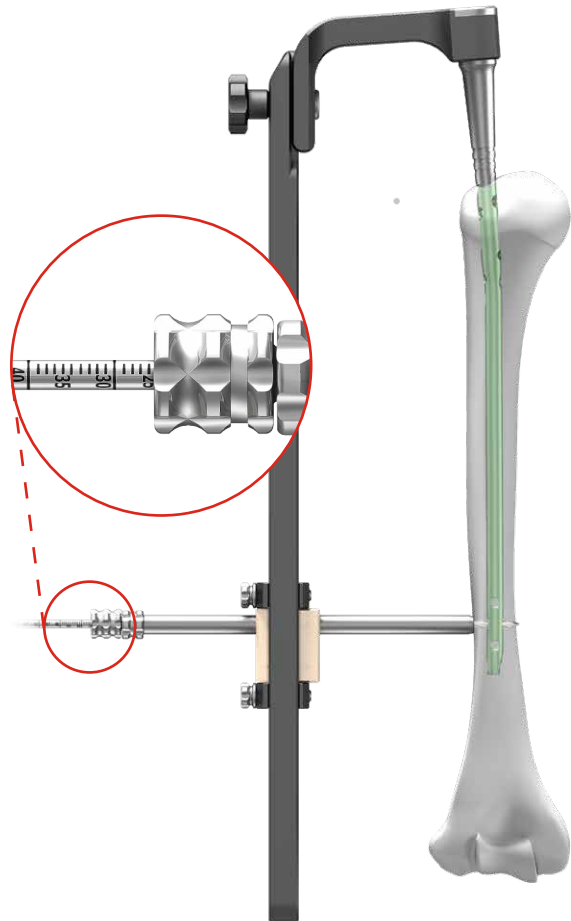

13 Mark the entry point to make the canal for the second locking screw insertion.



Repeat step 11.

14 Perform a hole in the bone to insert the second locking screw.



Repeat step 12.

Remove the drill [40.5339.002] or [40.5342.002] and drill guide 7/3.5 [40.5511.200] directly after making the hole.

Leave the protective guide 9/7 [40.5510.200] in the slider hole.

	40.5339.002
	40.5342.002
	40.5511.200
	40.5510.200

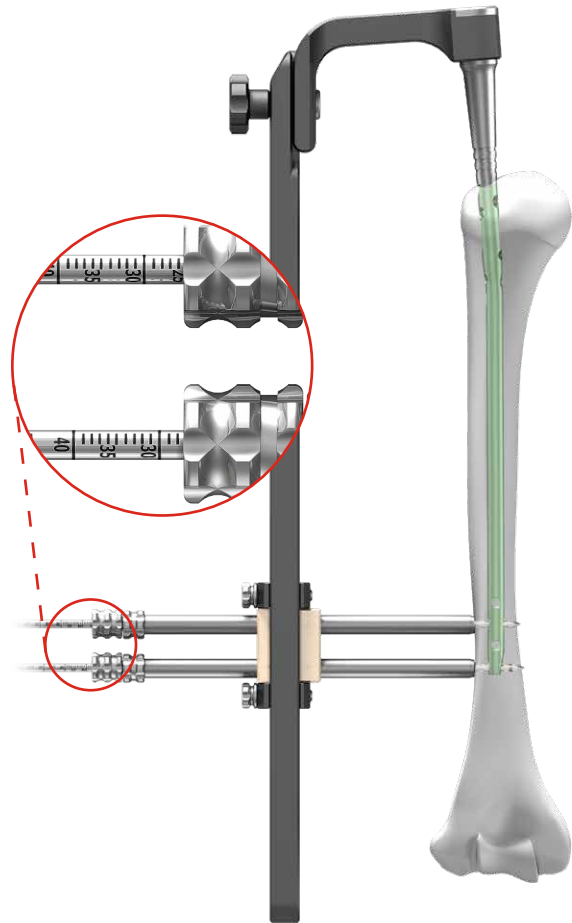

15 Implantation of 8÷10 mm nail (use 4.0/4.5 mm screws).

Insert the screw length measure [40.5530.100] through the protective guide 9/7 [40.5510.200] until its hook reaches the cortex on the other side of the bone. Read the length of the locking screw on the B-D scale.



When measuring, the end of the protective guide should rest on the cortical bone.

Remove the screw length measure. Leave the protective guide in the targeter slider.

	40.5510.200
	40.5530.100

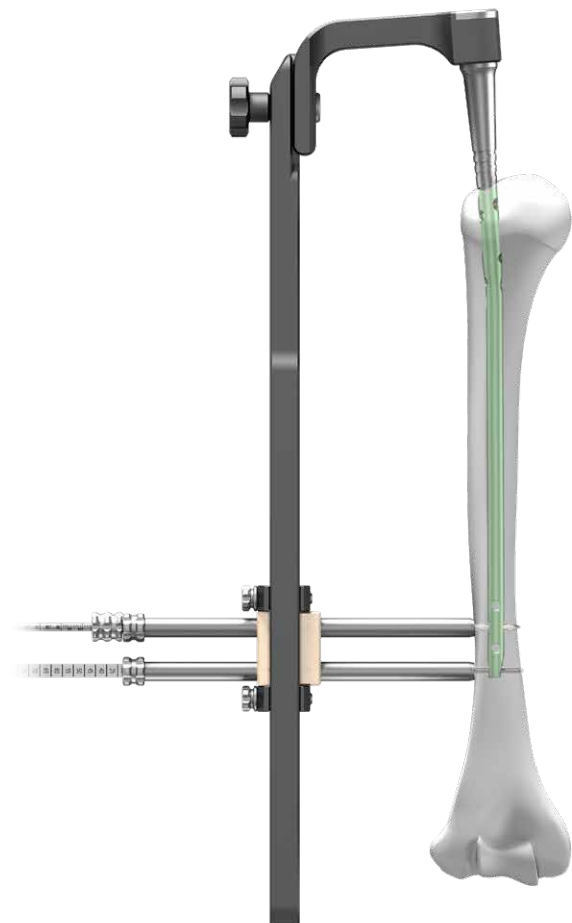

- 16** Insert the tip of the screwdriver T25 **[40.5575.400]** into the head of the determined locking screw. Then advance such system into the protective guide 9/7 **[40.5510.200]** and insert the locking screw into prepared hole until the head of the screw reaches the cortex bone (*the groove on the screwdriver shaft matches the edge of the protective guide*).

Remove the screwdriver.

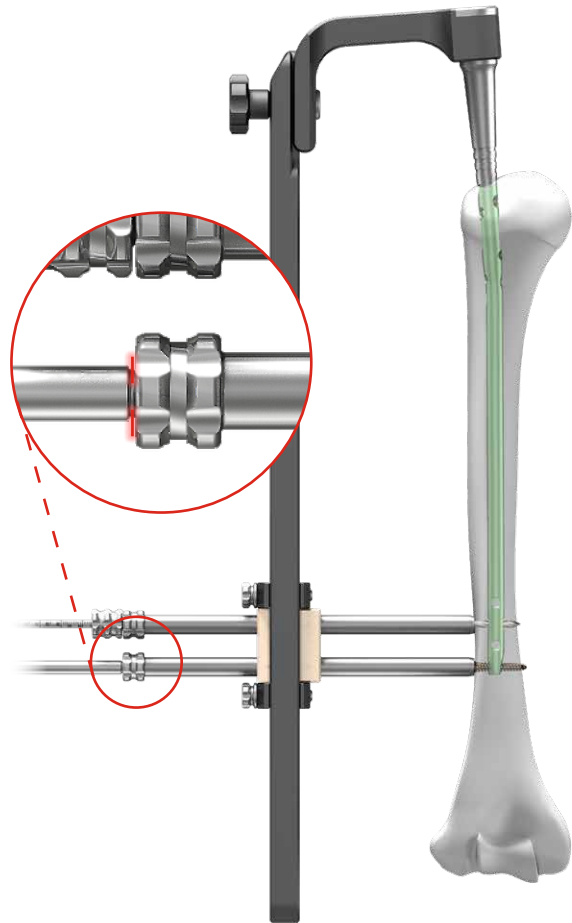
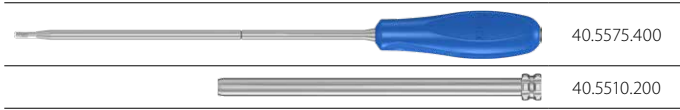

- 17** Remove the drill **[40.5339.002]** or **[40.5342.002]** and the drill guide **[40.5511.200]** from the slider hole of the targeter. Leave the protective guide **[40.5510.200]** in the slider hole. Insert the screw length measure **[40.5530.100]** through the protective guide, until its hook reaches the cortex on the other side of the bone.

Read the length of the locking screw on the B-D scale.



When measuring, the end of the protective guide should rest on the cortical bone.

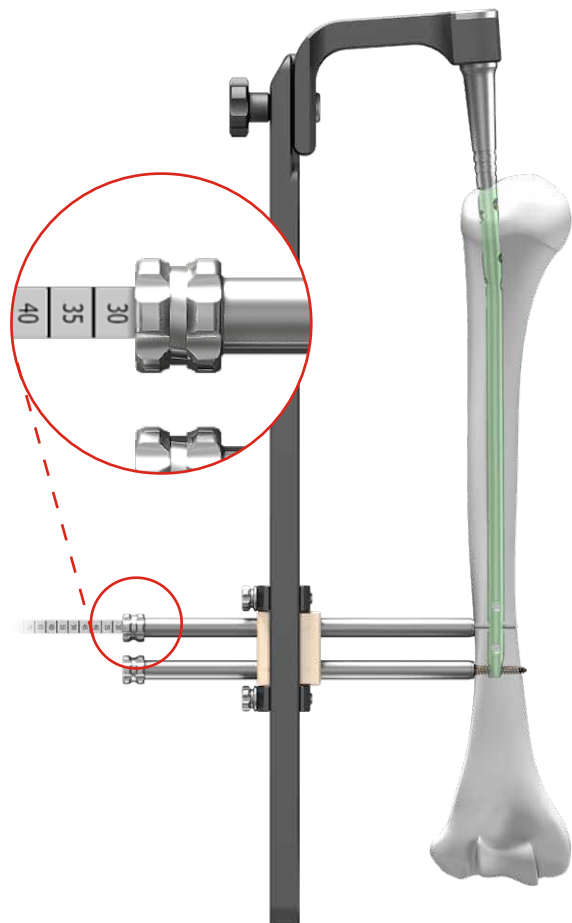
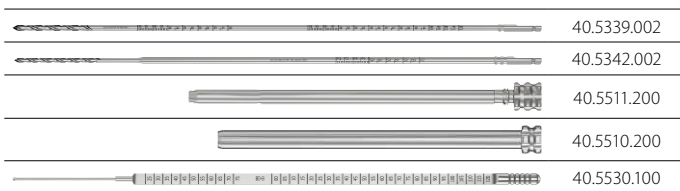

- 18** Insert the tip of the screwdriver T25 [40.5575.400] into the head of the determined locking screw. Then advance such system into the protective guide 9/7 [40.5510.200] and insert the locking screw into prepared hole until the head of the screw reaches the cortex bone (*the groove on the screwdriver shaft matches the edge of the protective guide*).

Remove the screwdriver, protective guides.

Remove distal targeter [40.5883.100] from the targeter arm [40.5881].

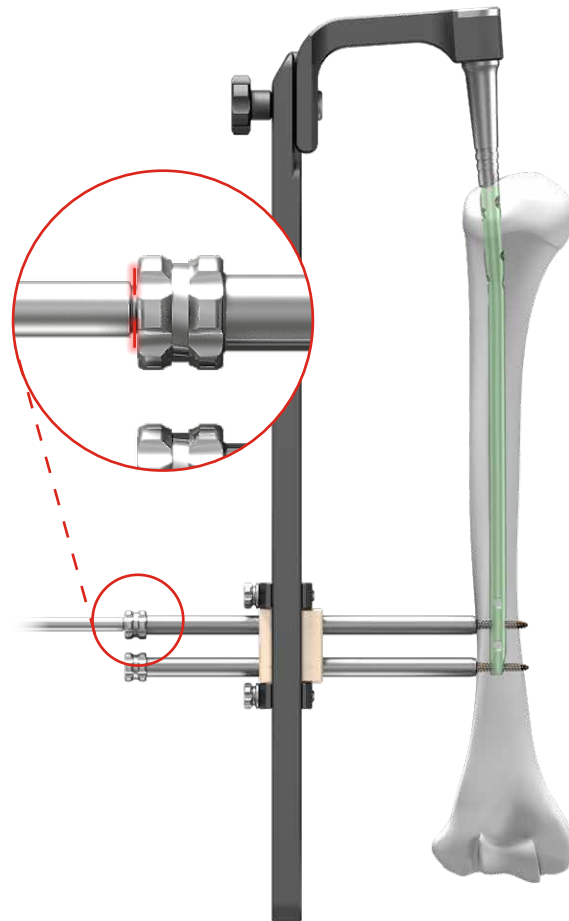
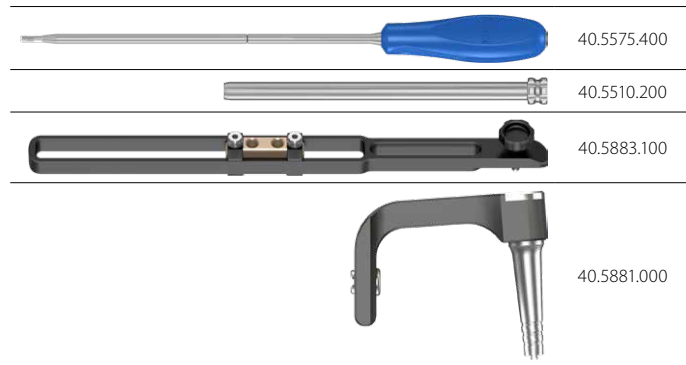

IV.2.6. DISTAL LOCKING OF THE NAIL USING "FREEHAND" TECHNIQUE



With this method, current radiological control is required to determine the drilling site and to control the drilling process.

It is recommended to use angular attachment with the surgical drive while drilling the holes, so that surgeon's hands are not directly exposed to X-Rays. After marking the entry points on the skin, make 1.5cm incisions in the marked places through the soft tissues.

- 19 Using X-Ray device, position the protective guide short [40.5871.100] in line with the nail hole. The centers of the holes in the guide and the nail have to be in line. The teeth of the guide have to be deep in the cortex. Insert the short trocar 7 [40.1354.100] into the hole in the protective guide short, advance it until it reaches the cortex and mark the entry point for the drill.

Remove the trocar.
Leave the protective guide short in place.

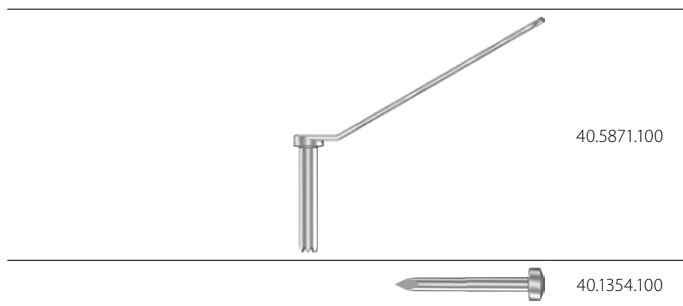

- 20 Drill the hole for locking screw insertion.

Option I

Implantation of 8÷10 mm nails (use 4,0/4,5 screws).

Insert the drill guide short [40.5872.100] into the protective guide short [40.5871.100]. Lead the drill with scale 3.5/350 [40.5339.002] into the drill guide, and drill the hole in the humerus through both cortical layers.

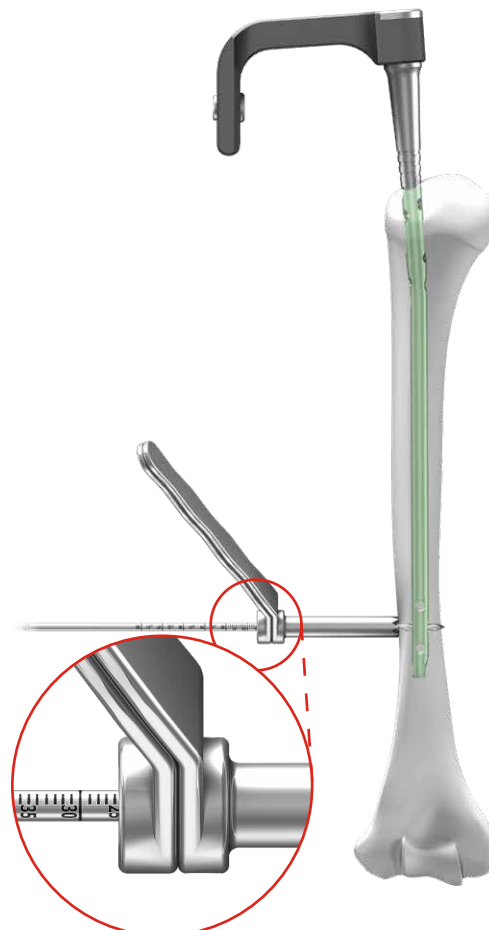
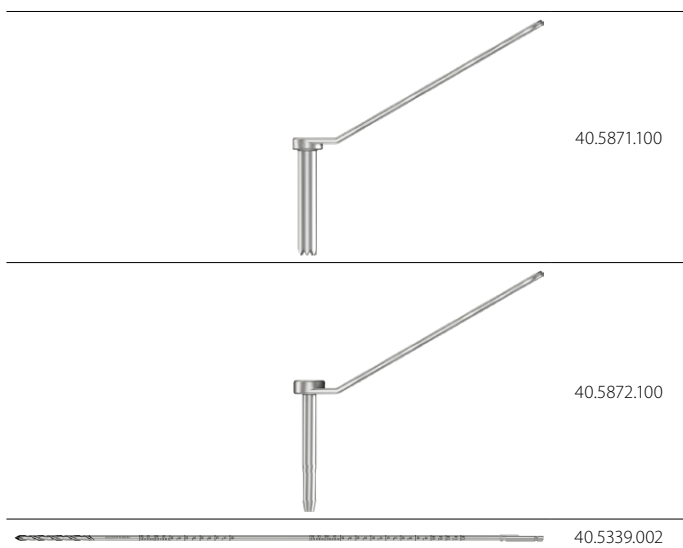

Option II

Implantation of 6 or 7 mm nails (use 3.0 screws).

Insert the drill guide short 7/2.5 [40.5892.100] into the protective guide short [40.5871.100]. Lead the drill with scale 2.5/320 [40.5342.002] into the drill guide, and drill the hole in the humerus through both cortical layers.

Remove the drill and drill guide.

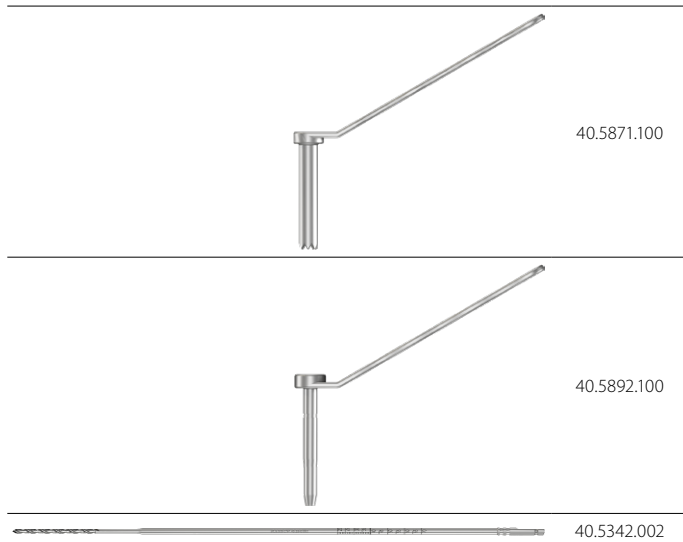

21 Implantation of 8 ÷10 mm nail (use 4.0/4.5 mm screws).
 Insert the screw length measure [40.5530.100] through the hole of the protective guide short [40.5871.100] into the drilled hole until its hook reaches the cortex on the other side of the bone. Read the length of the locking screw on the scale D of the measure.

Remove the screw length measure.
 Leave the protective guide short in place.

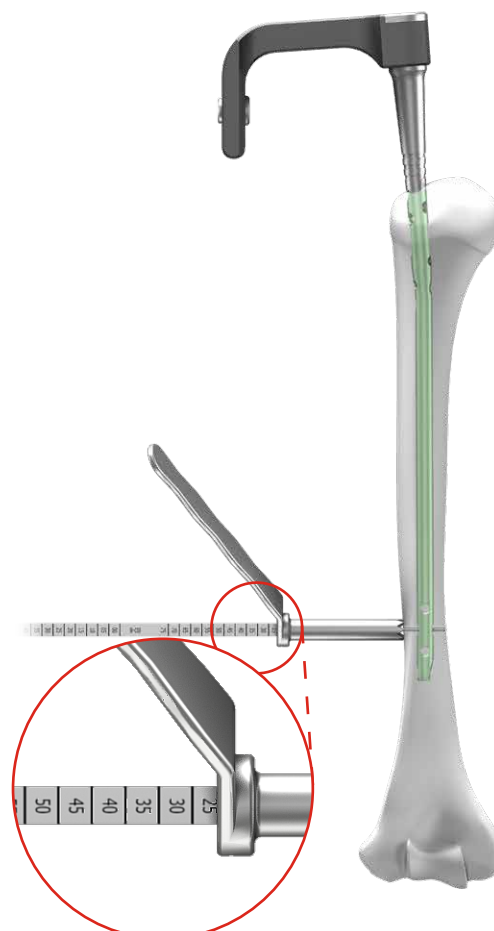
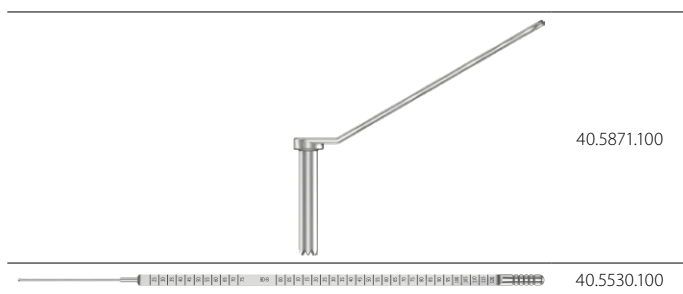

- 22** Insert the tip of the screwdriver T25 **[40.5575.400]** into the head of the determined locking screw. Then advance such system into the protective guide short **[40.5871.100]** and insert the locking screw into prepared hole until the head of the screw reaches the cortex bone.

Remove the screwdriver and protective guide short.

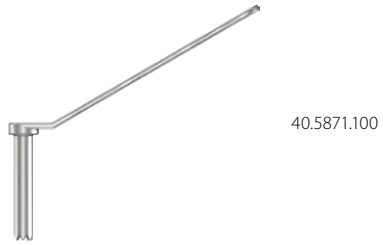

The process of locking the nail in the second distal hole shall be carried out using description of Chapter IV.2.6 DISTAL LOCKING OF THE NAIL USING "FREEHAND" TECHNIQUE, described in steps 19÷22.



IV.2.7. PROXIMAL LOCKING OF THE NAIL

IV.2.7.1. Fixation with compression

23 Mount the proximal targeter [40.5882.100] to the targeter arm [40.5881].



In fixation with compression, large and medial hole of the proximal targeter and the protective guide 18/7.0 [40.5035.100] shall be used.



40.5882.100



40.5881.000



40.5035.100



- 24** Insert the protective guide 18/7.0 **[40.5035.100]** with the trocar 6.5 **[40.5534.100]** into the proximal targeter **[40.5882.100]** hole. Mark on the skin the entry point for locking screw using the trocar and make adequate 4 cm incision through the soft tissues. Advance the protective guide and the trocar into prepared incision until the tip reaches the cortical bone. Using the trocar, mark the entry point for the drill.

Remove the trocar.

Leave the protective guide in the hole of the targeter.

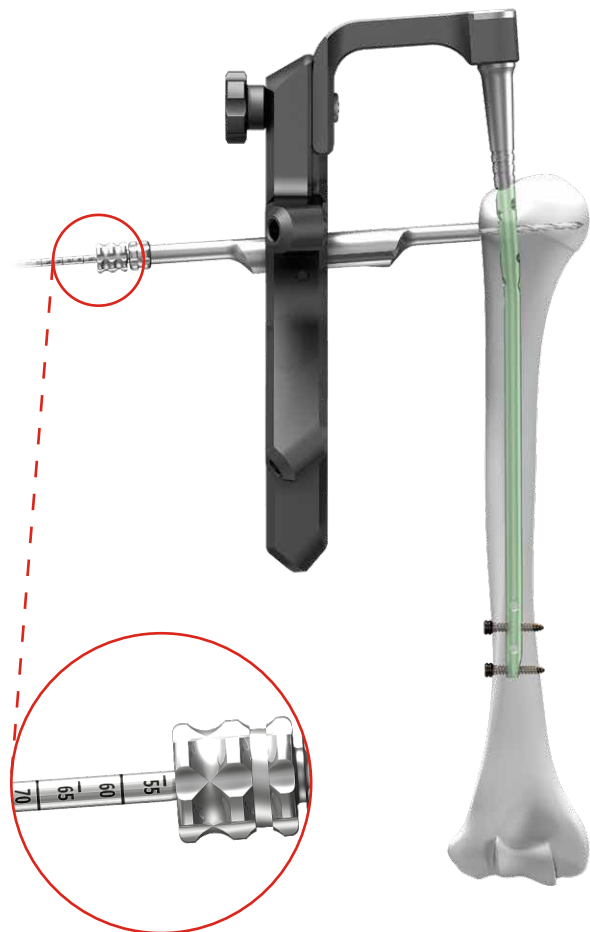
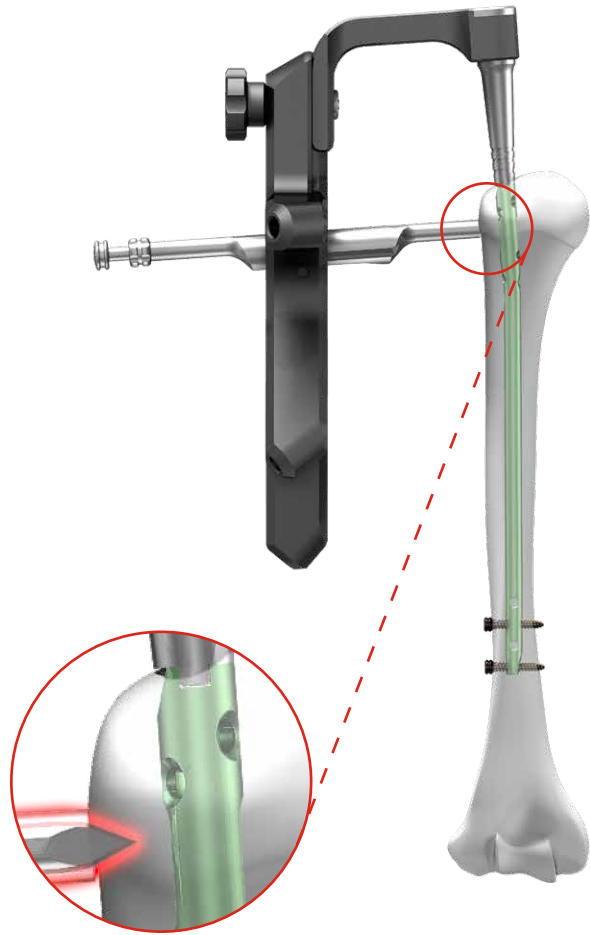

- 25** Insert the drill guide 7/3.5 **[40.5511.200]** into the protective guide 18/7.0 **[40.5035.100]**. Mount the drill 3.5/350 **[40.5339.002]** to the surgical drive and advance such system through the drill guide. Drill the hole for the locking screw under the X-Ray control. Read the length of the locking screw on the scale of the drill.



When measuring, the end of the protective guide should rest on the cortical bone.

Remove the drill and the drill guide.

Leave the protective guide **[40.5035.100]** in the hole of the targeter **[40.5882.100]**.



- 26** Insert the tip of the screwdriver T25 **[40.5575.400]** into the head of the determined locking screw. Then advance such system into the protective guide 18/7.0 **[40.5035.100]** and insert the locking screw into prepared hole until the head of the screw reaches the cortex bone (*the groove on the screwdriver shaft matches the edge of the protective guide*).

Remove the screwdriver and protective guide.

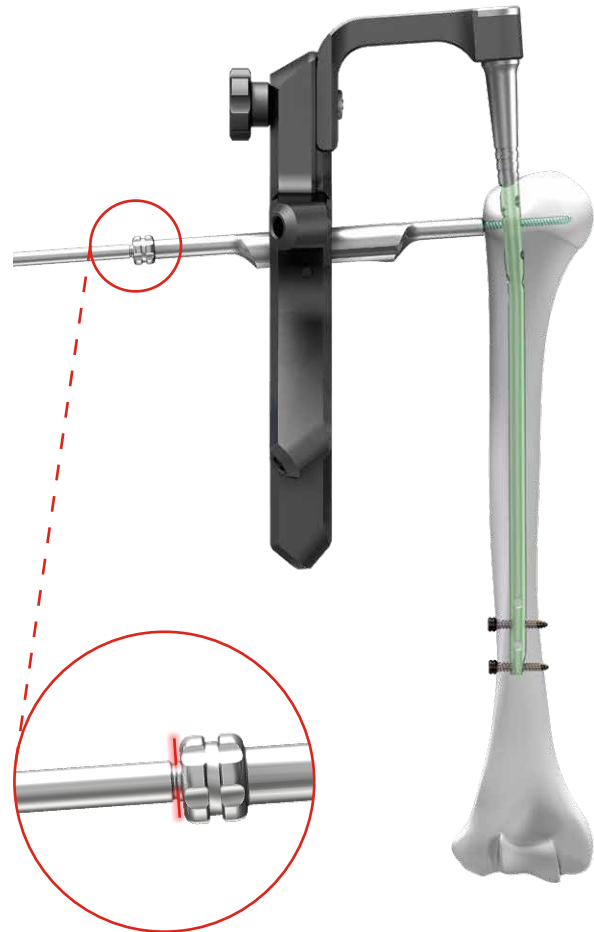
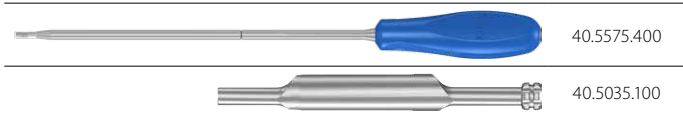

- 27** Insert the compression screw **[40.5887]** into the connecting screw **[40.5884]** to perform the compression of bone fragments.

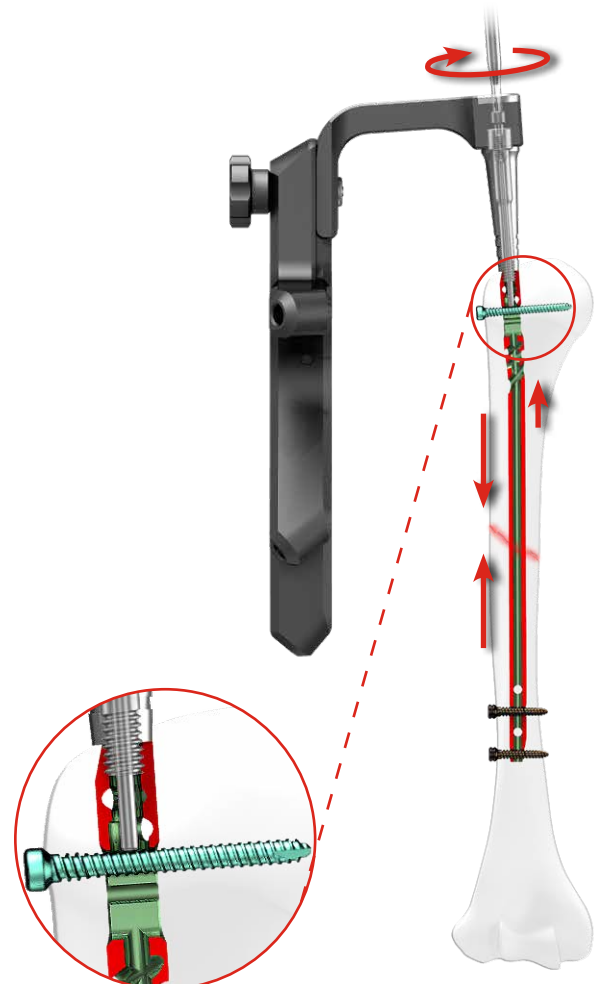

- 28** To preserve performed compression, insert at least one locking screw into the hole for static locking.

Remove the compression screw [40.5887].

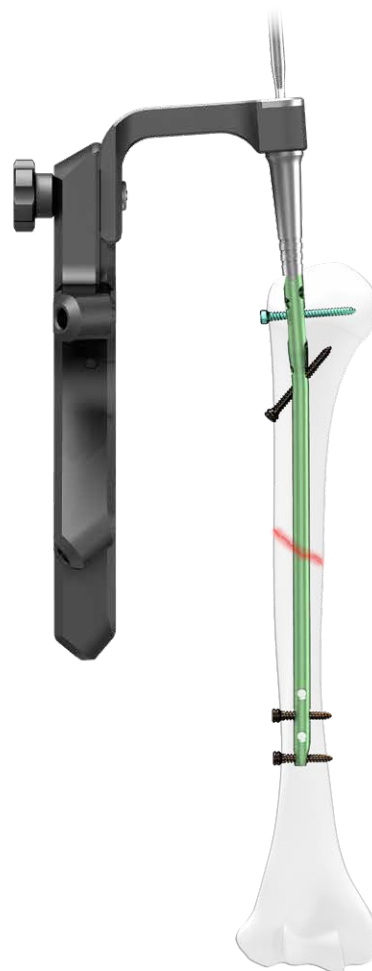

IV.2.7.2. Static fixation

Mount the proximal targeter [40.5882.100] on the targeter arm [40.5881].



In the static fixation, in the proximal part, use holes on the targeter arms and one oblique hole.



40.5882.100



40.5881.000



29 Insert the protective guide 9/7 [40.5510.200] with trocar 6.5 [40.5534.100] in selected hole of the proximal targeter [40.5882.100]. After marking the entry point of the locking screw on the skin, make 1.5 cm incision through the soft tissues. Advance the protective guide with the trocar into prepared incision until it reaches the cortical bone. Using the trocar, mark the entry point for the drill.

Remove the trocar.

Leave the protective guide in the hole of the targeter.

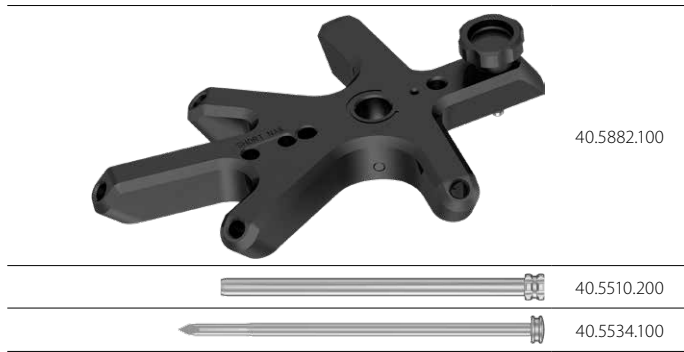

29a **Optional**

Insert cutter 7.0 [40.5897] in the left protective guide 9/7 [40.5510.200]. Manually turn the instrument to prepare the bone for drill insertion.

Remove the cutter 7.0

Leave protective guide in the targeter.

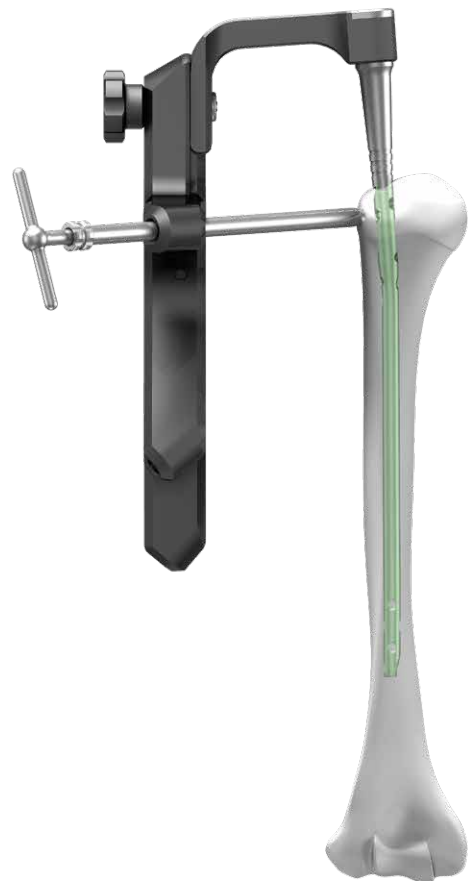
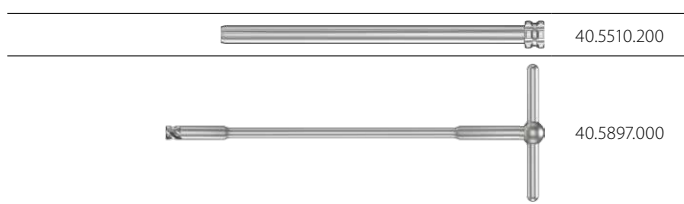

30 Drill the hole in the humeral bone for locking screw insertion.

Insert the drill guide 7/3.5 mm **[40.5511.200]** into the protective guide 9/7 **[40.5510.200]**. Using the surgical drive and guiding the drill 3.5/350 **[40.5339.002]** in the drill guide, drill under X-Ray control the hole for locking screw. The scale on the drill indicates the length of locking element.

Remove the drill and drill guide.

Leave the protective guide in the hole of the targeter.

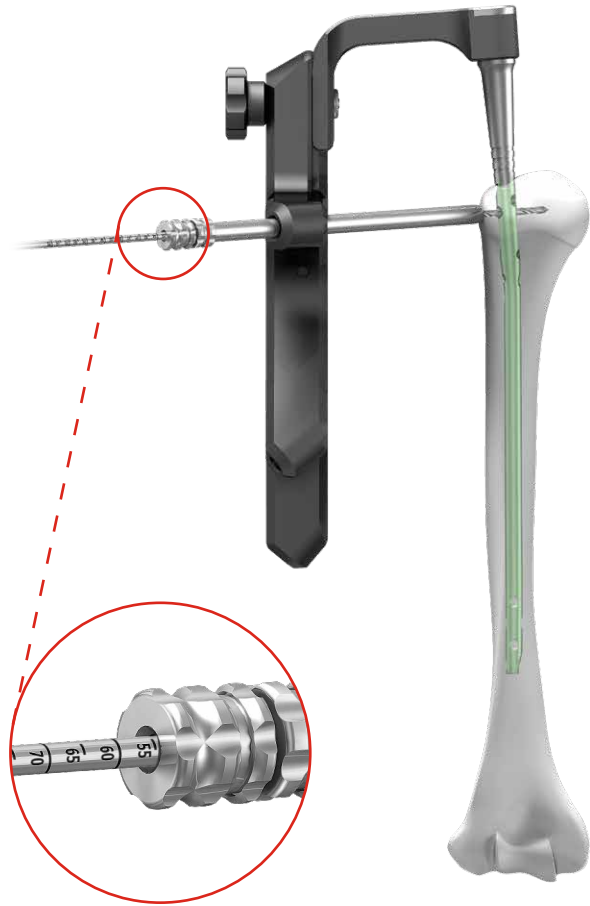
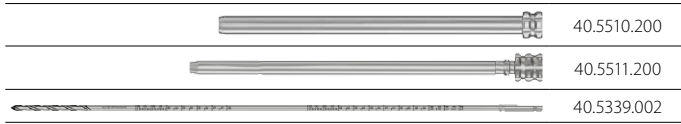

31 Insert the screw length measure **[40.5530.100]** through the protective guide **[40.5510.200]** into drilled hole until its tip reaches the end of the hole. Read the length of the locking screw on the B-D scale.



When measuring, the end of the protective guide should rest on the cortical bone.

Remove the screw length measure.

Leave the protective guide in the hole of the targeter.

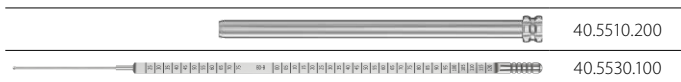

32 Insert the tip of the screwdriver T25 [40.5575.400] into the head of the determined locking screw. Then advance such system into the protective guide 9/7 [40.5510.200] and insert the locking screw into prepared hole until the head of the screw reaches the cortex bone (*the groove on the screwdriver shaft matches the edge of the protective guide*).

Remove the screwdriver, protective guide and proximal targeter

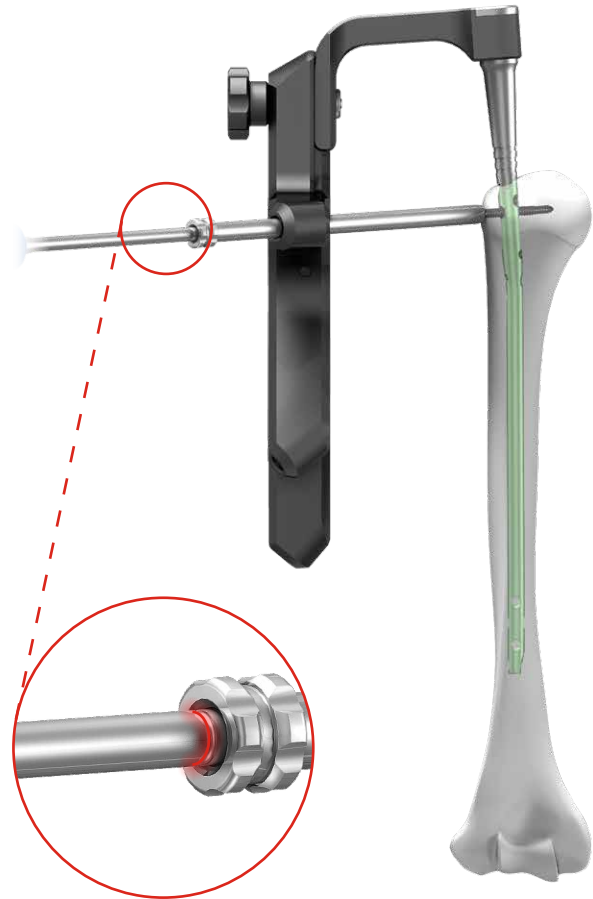
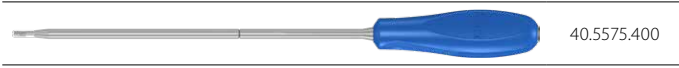

If the surgeon decides to lock the nail in the proximal part with additional locking screws, then locking of the nail should be performed as shown in stages 29÷32 described in chapter IV.2.7.2. selecting another hole in the arm of proximal targeter.

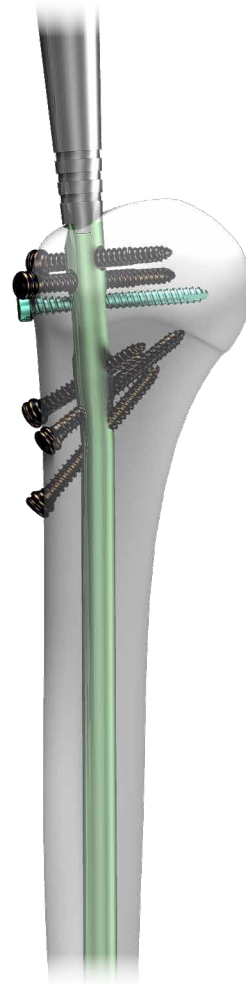

IV.2.7.3. Oblique locking of the nail

Design of the proximal targeter **[40.5882.100]** enables oblique insertion of locking screw in the proximal part of the nail and compression using the compression screw through the holes of the targeter.

Mount the proximal targeter **[40.5882.100]** to the targeter arm **[40.5881]**.

Before oblique locking of the nail, verify with the X-Ray device the mutual position of the holes in the targeter and the holes in the proximal part of the intramedullary nail.



In oblique proximal locking of the nail, one out of two oblique holes of the proximal targeter **[40.5882.100]** shall be used.



40.5882.100



40.5881.000



- 33** Insert the protective guide 9/7 [40.5510.200] with trocar 6.5 [40.5534.100] into the selected oblique hole of proximal targeter [40.5882.100].



In the oblique locking, the insertion of the locking screw can be performed only in one direction as it goes through the long hole of the nail.

Mark on the skin the entry point for the locking screw and make adequate 1.5 cm incision through soft tissues. Then advance the protective guide with the trocar into prepared incision until the guide reaches the cortex bone.

Using the trocar mark the entry point for the drill.

Remove the trocar.

Leave the protective guide in the hole of the targeter.

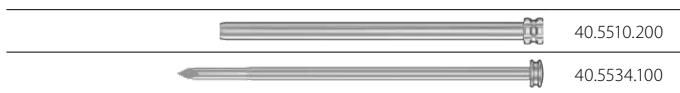

- 34** Drill the hole in the humeral bone for locking screw insertion.
Insert the drill guide 7/3.5 [40.5511.200] into the protective guide 9/7 [40.5510.200]. Using the surgical drive and guiding the drill 3.5/350 [40.5339.002] in the drill guide, drill under X-Ray control the hole for locking screw. The scale on the drill indicates the length of the locking element.

Remove the drill and drill guide.

Leave the protective guide in the hole of the targeter.

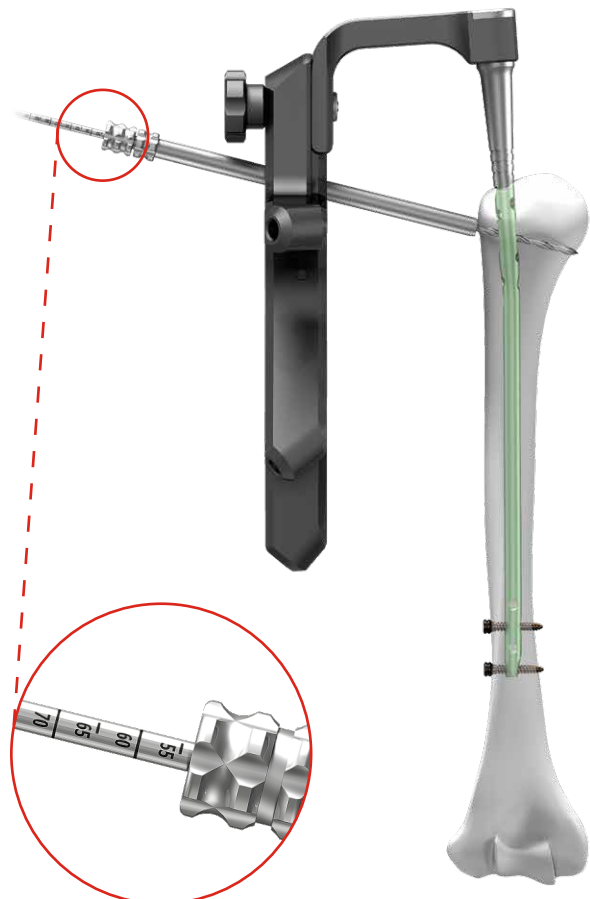
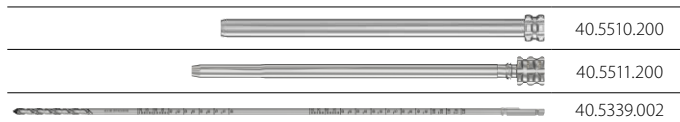

- 35** Insert the screw length measure [40.5530.100] through the protective guide [40.5510.200] into drilled hole until its tip reaches the end of the hole. Read the length of the locking screw on the B-D scale.

Remove the screw length measure.

Leave the protective guide in the hole of the targeter.

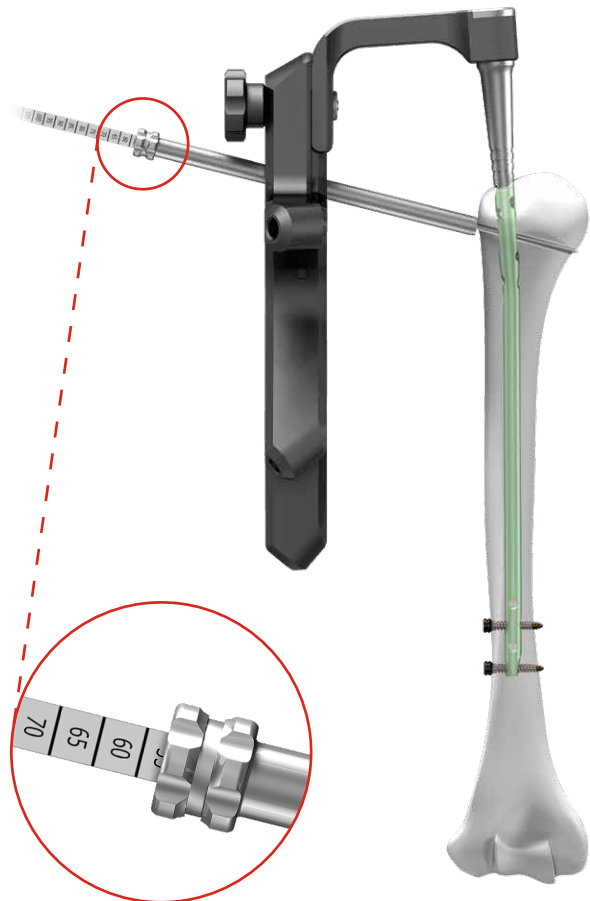
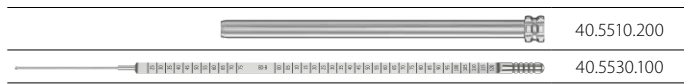

- 36** Insert the tip of the screwdriver T25 [40.5575.400] into the head of the determined locking screw.



In oblique locking of the nail, 4.0 locking screws shall be used.

Then advance such system into the protective guide 9/7 [40.5510.200] and insert the locking screw into prepared hole until the head of the screw reaches the cortex bone (the groove on the screwdriver shaft matches the edge of the protective guide).

Remove the screwdriver and protective guide.

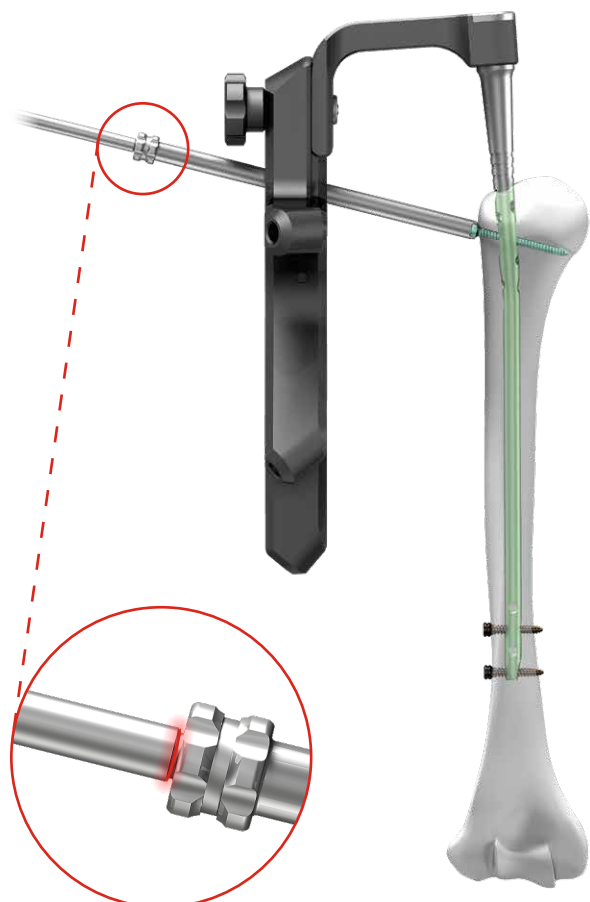
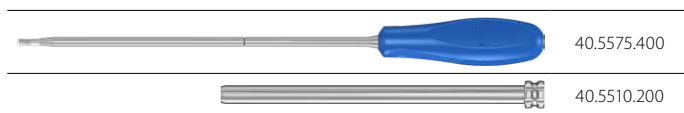

IV.2.8. Distal locking of the short nail



Use the holes marked SHORT NAIL of the proximal targeter [40.5882.100] when reducing fractures using a short nail (in its distal part).

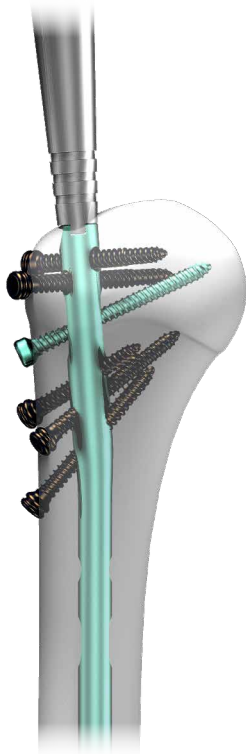

37 Insert the protective guide 9/7 [40.5510.200] with the trocar 6.5 [40.5534.100] in the selected distal hole of the proximal targeter [40.5882.100].

After marking the entry point of the locking screw on the skin, make 1.5 cm incision through the soft tissues.



40.5882.100

40.5510.200

40.5534.100



38 Advance the protective guide with the trocar into prepared incision until it reaches the cortical bone. Using the trocar mark the entry point for the drill.

Remove the trocar.

Leave the protective guide in the hole of the targeter.



39 Insert the drill guide 7/3.5 [40.5511.200] into the protective guide 9/7 [40.5510.200]. Using the surgical drive and guiding the drill 3.5/350 [40.5339.002] via drill guide, drill under X-Ray control the hole for locking screw. The scale on the drill indicates the length of the locking element.

Remove the drill and drill guide.

Leave the protective guide in the hole of the targeter.

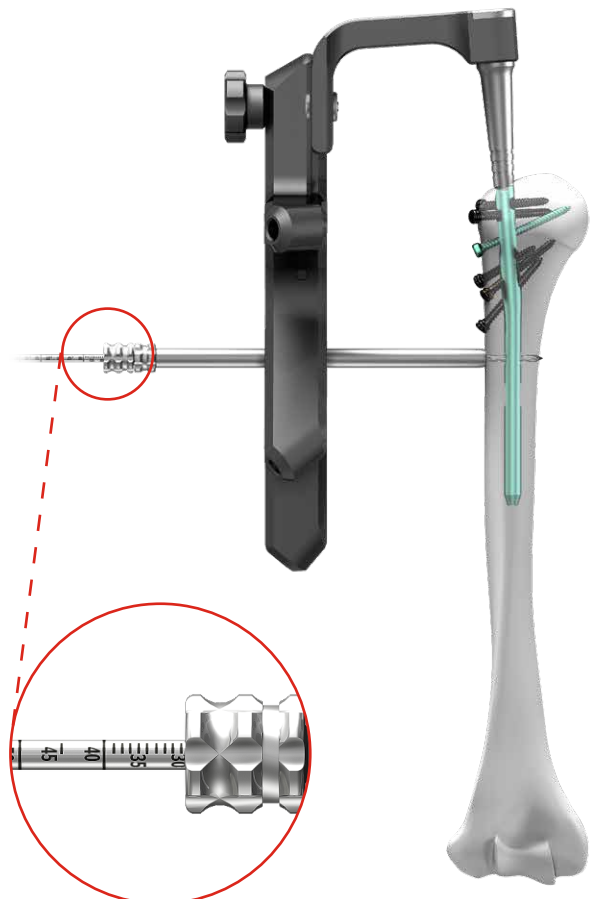
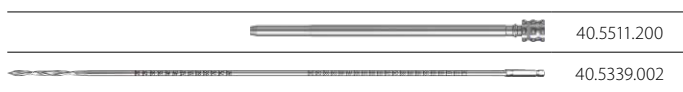

40 Insert the screw length measure [40.5530.100] through the protective guide 9/7 [40.5510.200] into drilled hole until its tip reaches the end of the hole.

Read the length of the locking screw on the B-D scale. When measuring, the end of the protective guide should rest on the cortical bone.

Remove the screw length measure.

Leave the protective guide in the hole of the targeter.

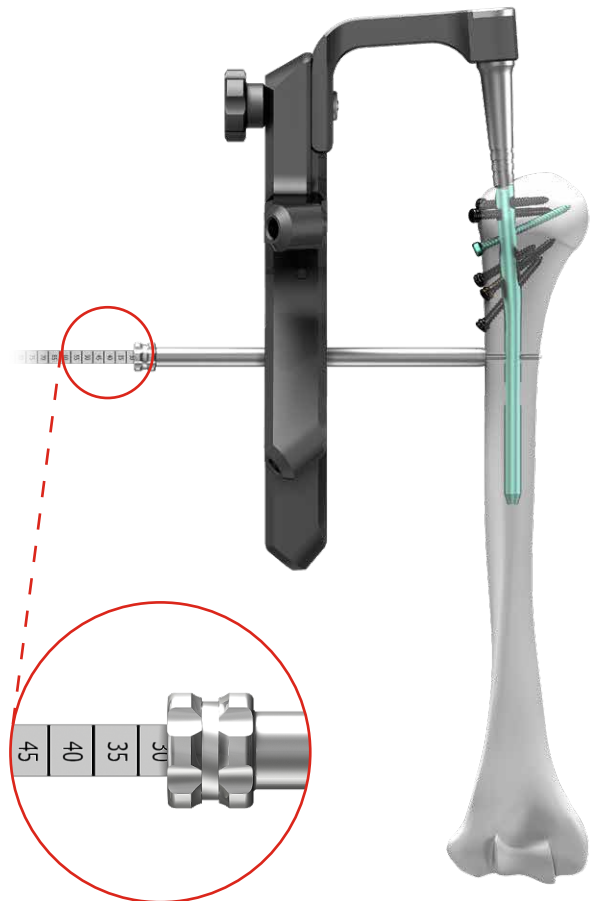
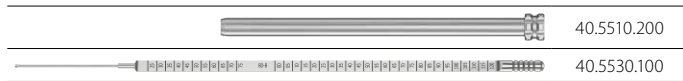

41 Insert the tip of the screwdriver T25 [40.5575.400] into the head of the determined locking screw. Then advance such system into the protective guide 9/7 [40.5510.200] and insert the locking screw into prepared hole until the head of the screw reaches the cortex bone (*the groove on the screwdriver shaft matches the edge of the protective guide*).

Remove the screwdriver and protective guide.

Remove proximal targeter.



If the surgeon decides to lock the nail in the distal part with additional locking screws, then locking of the nail should be performed as shown in Chapter IV.2.8, selecting the next hole in the proximal targeter.

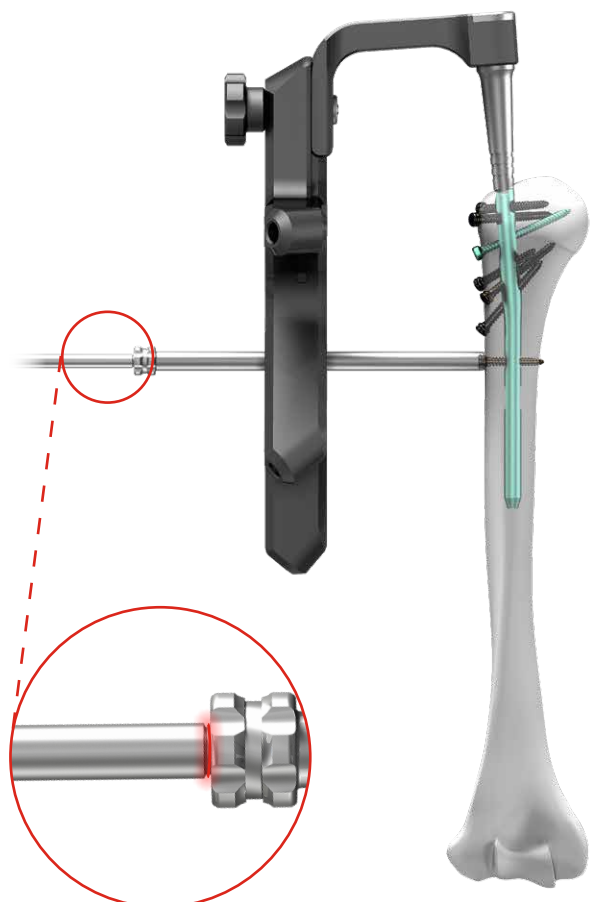
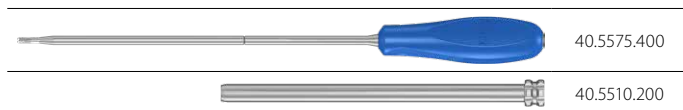

IV.3. DISTAL HUMERAL NAIL INSERTION

IV.3.1. Patient positioning

Place the patient prone
It is recommended to abduct the arm and set the forearm downwards.

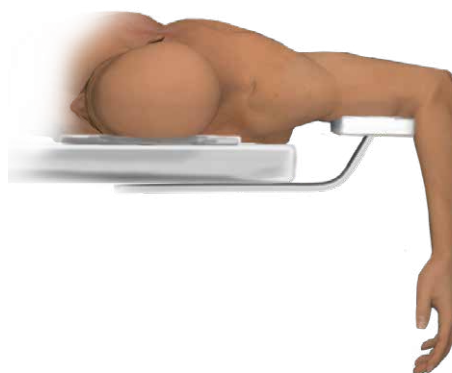

IV.3.2. PREPARING TO OPEN THE MEDULLARY CANAL

When performing distal nailing, prepare the surgical approach through a longitudinal 40mm-skin incision near the olecranon in the direction of the proximal part of the bone. Do not open the elbow joint. When the opening point for the nail insertion is determined, using electric drive and drill with scale 3.5/150 [40.5343.002] perform three holes in the form of a triangle.



This procedure must be performed under the X-Ray with video channel control.



IV.3.3. MEDULLARY CANAL OPENING

It is recommended to open the medullary canal with technique described in steps 1 and 2. The chosen surgical technique depends on surgeon's preference and available equipment in the operation suite.

Opening of the medullary canal shall be performed with the use of curved cannulated awl [40.5523] for the depth of about 5 cm.



This procedure must be performed under the X-Ray with video channel control.

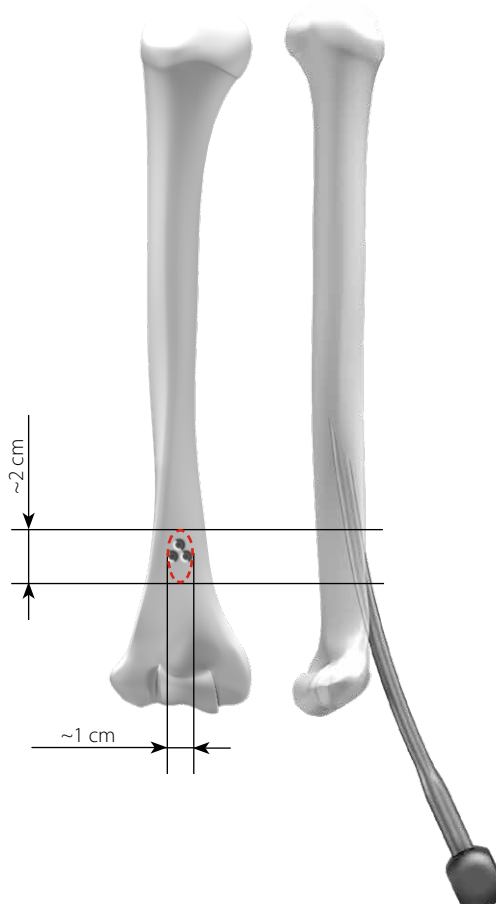
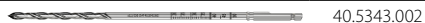

IV.3.4. Canal preparation

Reamed canal

42 Insert the guide rod 2.5/580 [40.3673.580] into the medullary canal to the appropriate depth, reducing the fracture at the same time. Gradually widen the medullary canal using flexible reamers with 0.5mm increments, until reaching the diameter which is 0.5mm wider than the diameter of the humeral nail, for the depth not lesser than the nail length. The proximal part of the medullary canal should be reamed to the diameter of 11mm, to the depth of approx. 7cm. (*proximal part of the nail is wider than its distal part*).

Remove the flexible reamer.
Leave the guide rod [40.3673.580] in the medullary canal.

When using a different guide (*guide rod*) for the reamer than the guide rod 2.5/580 included in the instrument set, the guide should be replaced with the guide rod 2.5/580 [40.3673.580] for measuring the nail length. Having reamed the canal, using the flexible reamer guide, insert teflon pipe guide 7/290 [40.3699] into the medullary canal. Remove the reamer guide. Install guide rod 2.5/580 [40.3673.580] (*cannulated nail guide*) in the guide rod handle [40.1351] and then insert into teflon pipe guide 7/290 to the required depth. Remove the guide rod handle and teflon guide.

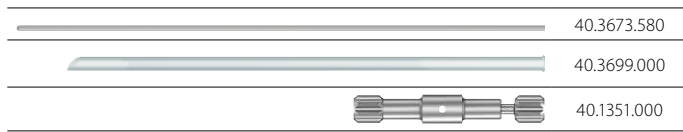

43 Place the nail length measure [40.5098] onto the guide rod 2.5/580 until it contacts the bone. The end of the guide rod [40.3673.580] indicates the implant length.

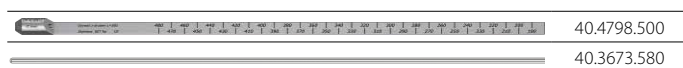

44 In the case of using solid nail, remove the guide rod [40.3673.580] from the medullary canal using the guide rod handle [40.1351].

The medullary canal is prepared for the humeral nail insertion.

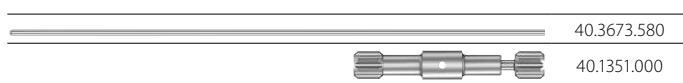

IV.3.5. TARGETER ARM AND NAIL ASSEMBLY. DISTAL TARGETER POSITIONING

- 45 Using the wrench S8 [40.5304] and the connecting screw M6x1 spec. L-62[40.5884], mount the intramedullary nail to the targeter arm [40.5881].
- 46 Mount the distal targeter [40.5883.100] onto the targeter arm [40.5881].
- 47 Using two set blocks 9/4.0/3.0 [40.5890.100], position the slider of the targeter with distal locking holes of intramedullary nail. Lock the slider of the targeter using the screwdriver [40.5575.400].



CHECK:
Properly set and secured slider enables set blocks to smoothly hit the nail holes.

Remove set blocks from slider of the targeter. Remove distal targeter.

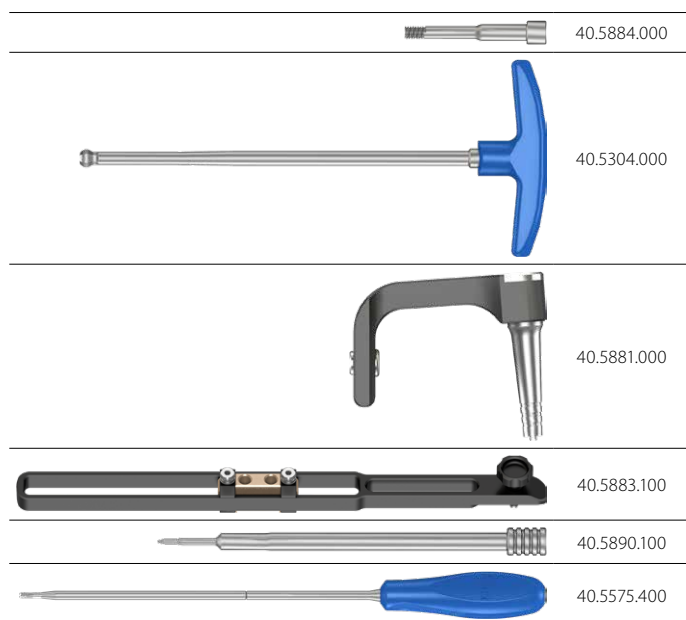

IV.3.6. NAIL INSERTION

- 48** Insert the humeral nail into the medullary canal until the desired depth is reached using the mallet [40.3667] and attached impactor-extractor [40.5308].



The cannulated nail shall be inserted into the medullary canal via the guide rod [40.3673.580].
The solid nail is inserted directly into the medullary canal (without using the guide rod).

Remove impactor-extractor from the targeter arm.
Remove the guide rod (only if cannulated nail has been implanted).

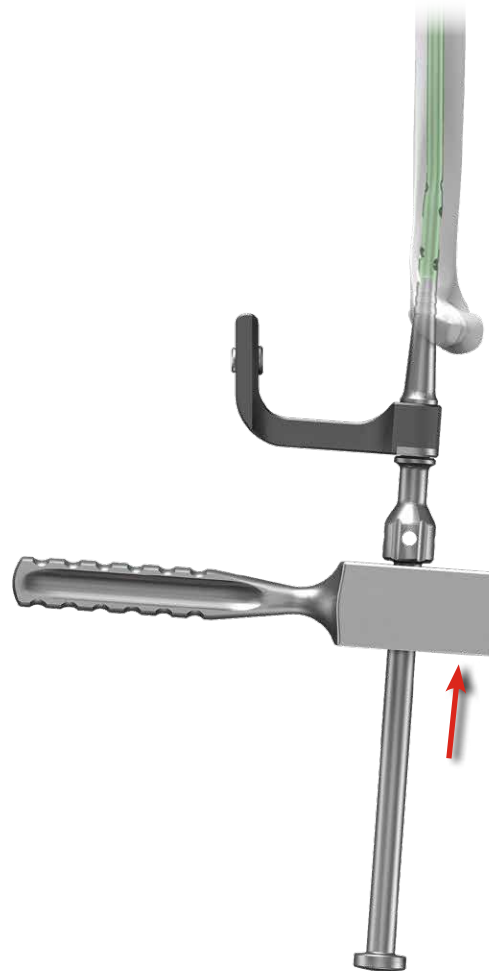
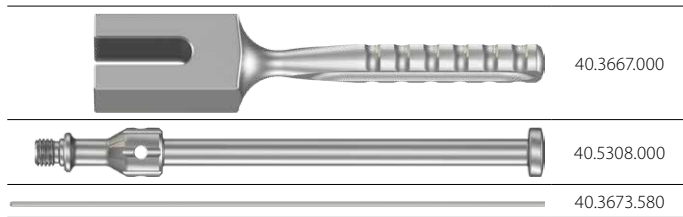

IV.3.7. PROXIMAL LOCKING OF THE NAIL

- 49** Attach distal targeter [40.5883.100] to the targeter arm [40.5881]. Before starting proximal locking, verify with X-Ray device and the aiming inserts 9.0 [40.5065.009] the mutual position of holes of the slider of the distal targeter and distal holes of the intramedullary nail.

Holes in the nail and the slider have to be in line - the image on the screen has to be of a circle shape (an image similar to the circle is allowed).

Insert respectively the protective guide 9/7 [40.5510.200] and the trocar 6.5 [40.5534.100] into the distal and then proximal hole of the distal targeter slider [40.5883.100]. Mark on the skin the entry point for the locking screw insertion. Make 1.5 cm incision.

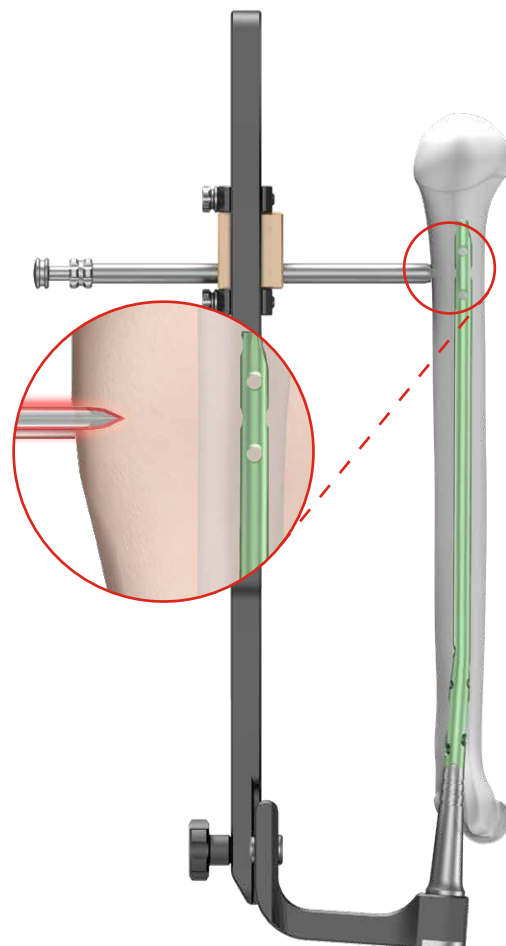
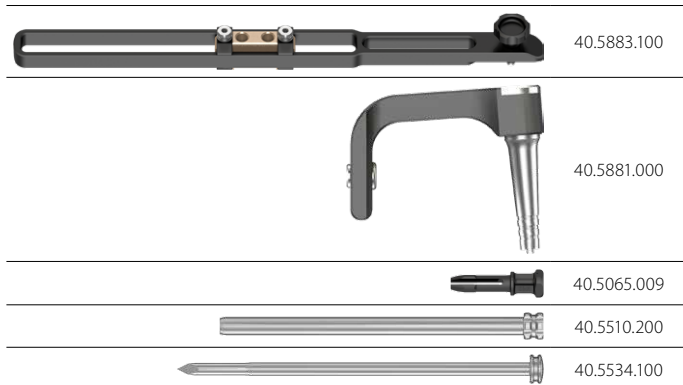

50 Insert protective guide 9/7 [40.5510.200] and trocar 6.5 [40.5534.100] into the slider hole of the distal targeter [40.5883.100]. Protective guide and trocar shall be inserted into the prepared incision until the end of the guide reaches cortical bone. Use the trocar to mark on the bone the entry point for the locking screw.

Remove the trocar.
Leave the protective guide in the slider hole.

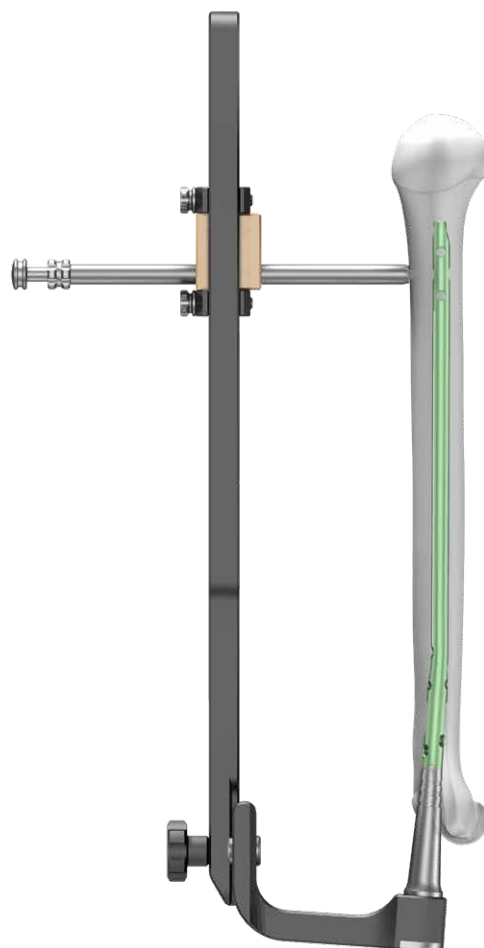
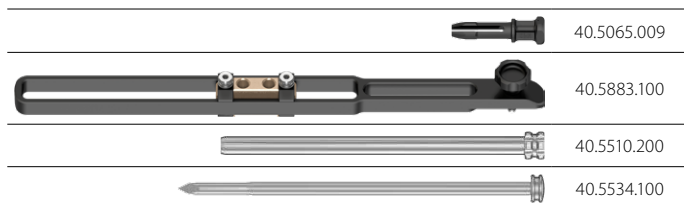

51 Drill the hole in the humeral bone for locking screw insertion.

Option I

Implantation of 8÷10 mm nail (use 4.0/4.5 mm screws).

Insert the drill guide 7/3.5 [40.5511.200] into the protective guide 9/7 [40.5510.200]. Mount the drill with scale 3.5/350 [40.5339.002] to the surgical drive and advance such system through the drill guide 7/3.5 [40.5511.200]. Drill the hole in the humerus through both cortical layers under the X-Ray control. The scale on the drill indicates the length of the locking element.

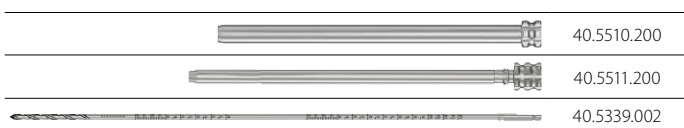

Option II

Implantation of 6 or 7mm nails (use 3.0 screws).

Insert the drill guide 7/3.5 [40.5511.200] into the protective guide 9/7 [40.5510.200]. Mount the drill with scale 2.5/320 [40.5342.002] to the surgical drive and advance such system through the drill guide 7/3.5 [40.5511.200]. Drill the hole in the humerus through both cortical layers under the X-Ray control. The scale on the drill indicates the length of the locking element. Disconnect the surgical drive and the drill. Leave in place the following system: protective guide – drill guide – drill.

	protective guide		drill guide		drill
Options I	[40.5510.200]	-	[40.5511.200]	-	[40.5339.002]
Options II	[40.5510.200]	-	[40.5511.200]	-	[40.5342.002]

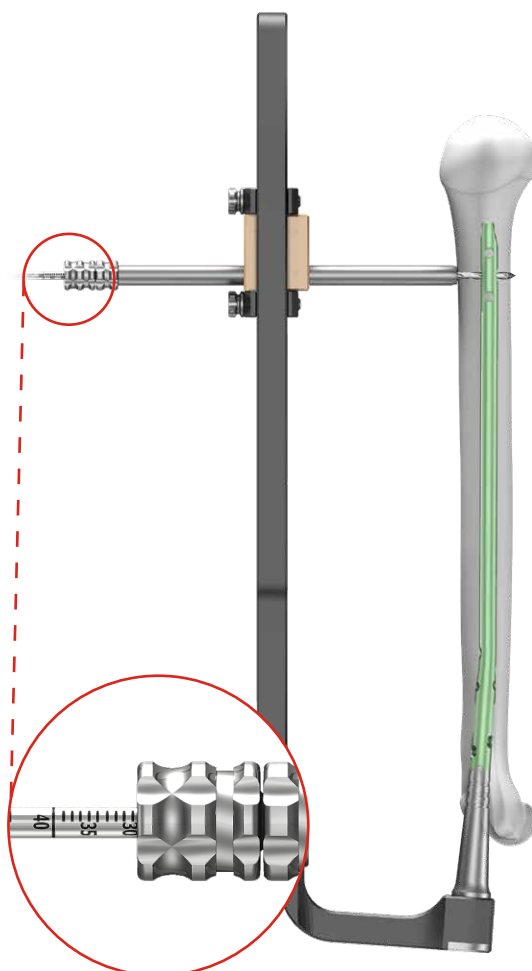

52 Mark the entry point to make the canal for the other locking screw insertion.



Repeat step **49** and **50**

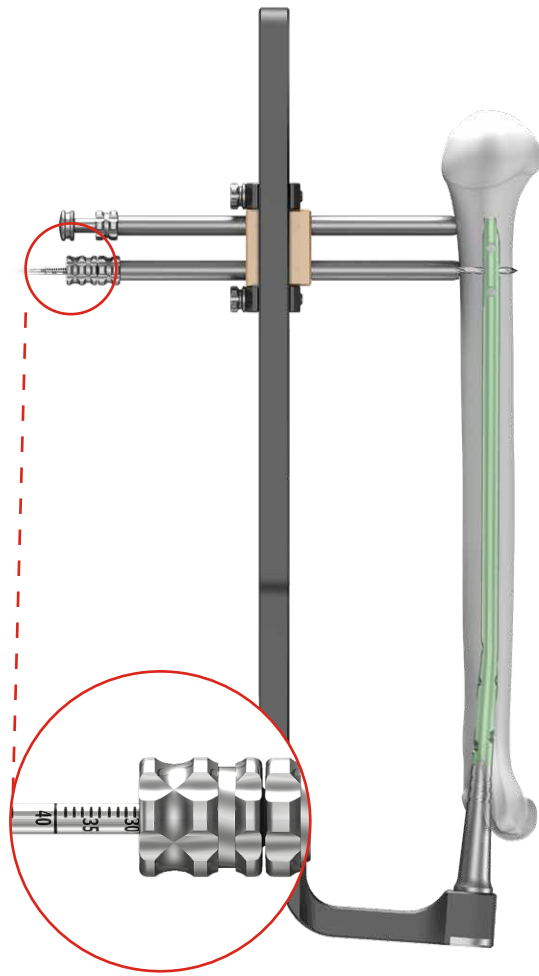

53 Perform a hole in the bone to insert the other locking screw.



Repeat step **51**

Remove the drill **[40.5339.002]** or **[40.5342.002]** and drill guide 7/3.5 **[40.5511.200]** directly after performing the hole.
Leave the protective guide 9/7 **[40.5510.200]** in the slider.

	40.5339.002
	40.5342.002
	40.5511.200

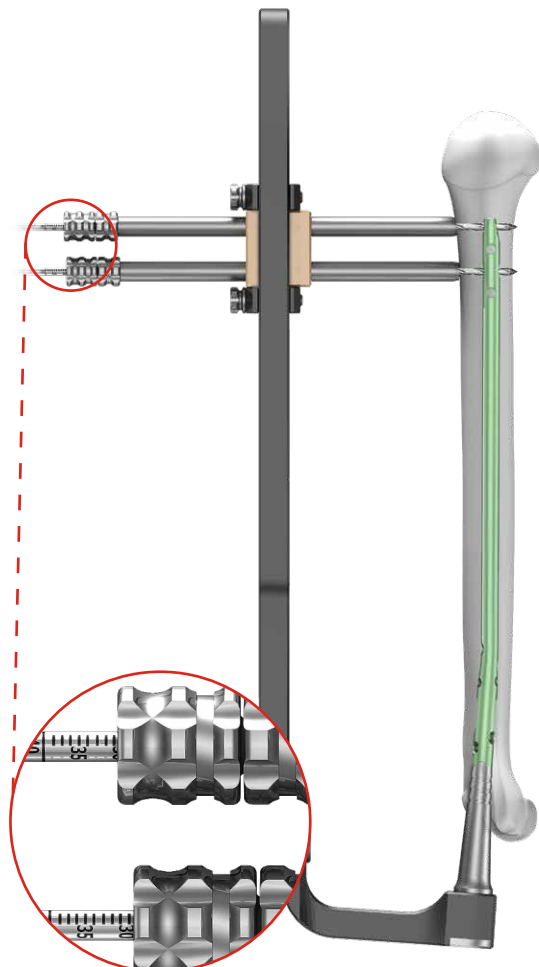

54 Implantation of 8+10 mm nail (use 4.0/4.5 mm screws).

Insert the screw length measure [40.5530.100] through the protective guide 9/7 [40.5510.200] until its hook reaches the cortex on the other side of the bone. Read the length of the locking screw on the B-D scale.



When measuring, the end of the protective guide should rest on the cortical bone.

Remove the screw length measure. Leave the protective guide in the targeter slider.

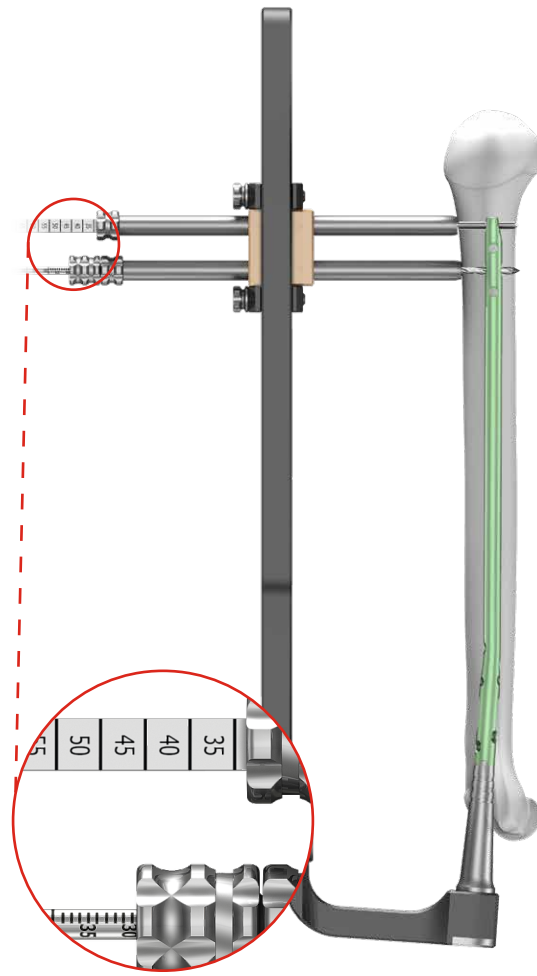
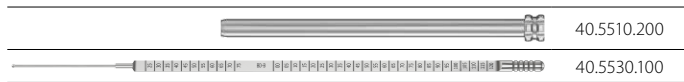

55 Insert the tip of the screwdriver T25 [40.5575.400] into the head of the determined locking screw. Then advance such system into the protective guide 9/7 [40.5510.200] and insert the locking screw into prepared hole until the head of the screw reaches the cortex bone (the groove on the screwdriver shaft matches the edge of the protective guide).

Remove the screwdriver.

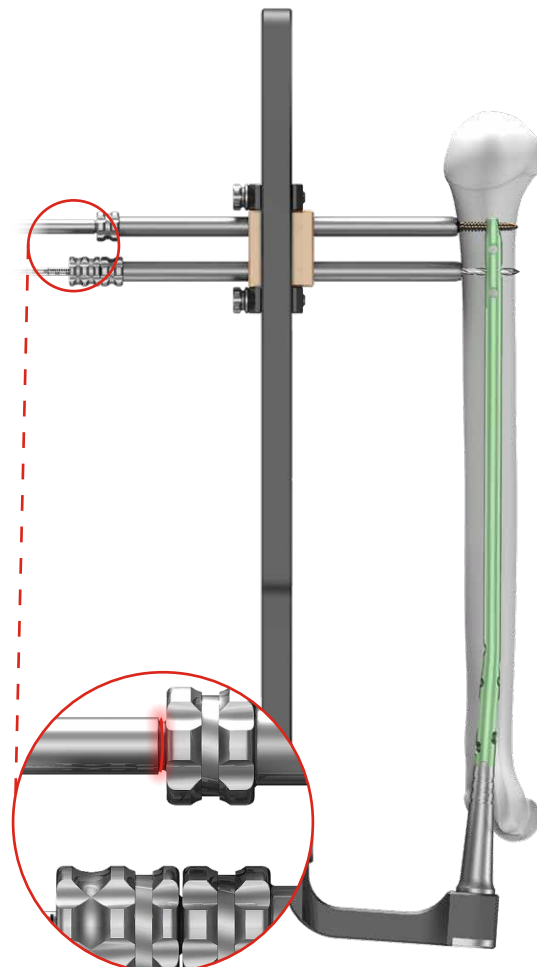
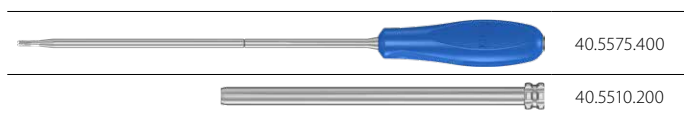

- 56** Remove the drill [40.5339.002] or [40.5342.002] and the drill guide 7/3.5 [40.5511.200] from the targeter slider. Leave the protective guide 9/7 [40.5510.200] in the slider hole.

Insert the screw length measure [40.5530.100] through the protective guide, until its hook reaches the cortex on the other side of the bone. Read the length of the locking screw on the B-D scale.



When measuring, the end of the protective guide should rest on the cortical bone.

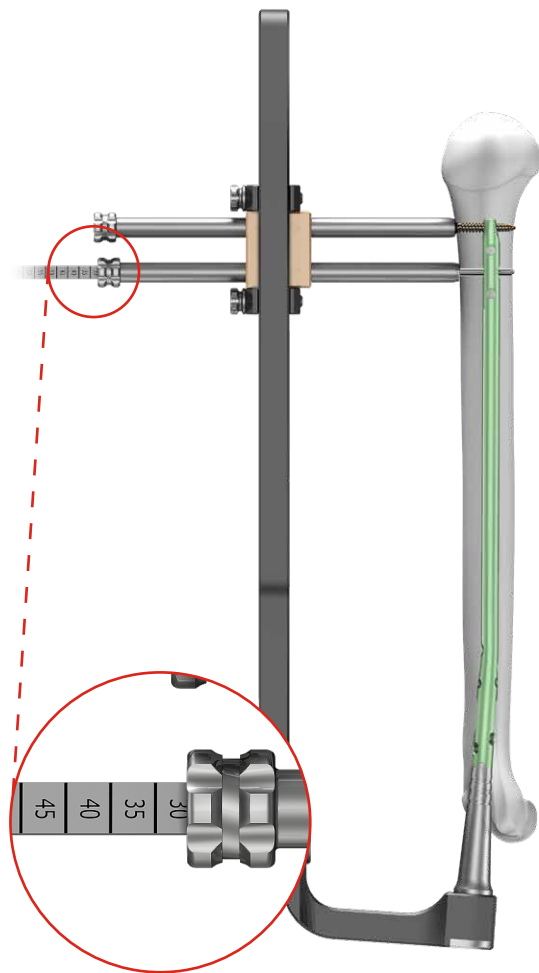
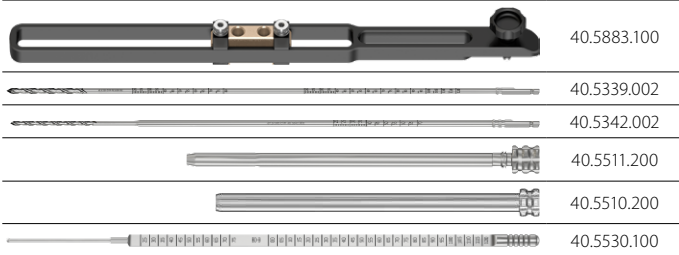

- 57** Insert the tip of the screwdriver T25 [40.5575.400] into the head of the determined locking screw. Then advance such system into the protective guide 9/7 [40.5510.200] and insert the locking screw into prepared hole until the head of the screw reaches the cortex bone (*the groove on the screwdriver shaft matches the edge of the protective guide*).

Remove the screwdriver and protective guides.

Remove distal targeter [40.5883.100] from the targeter arm [40.5881].

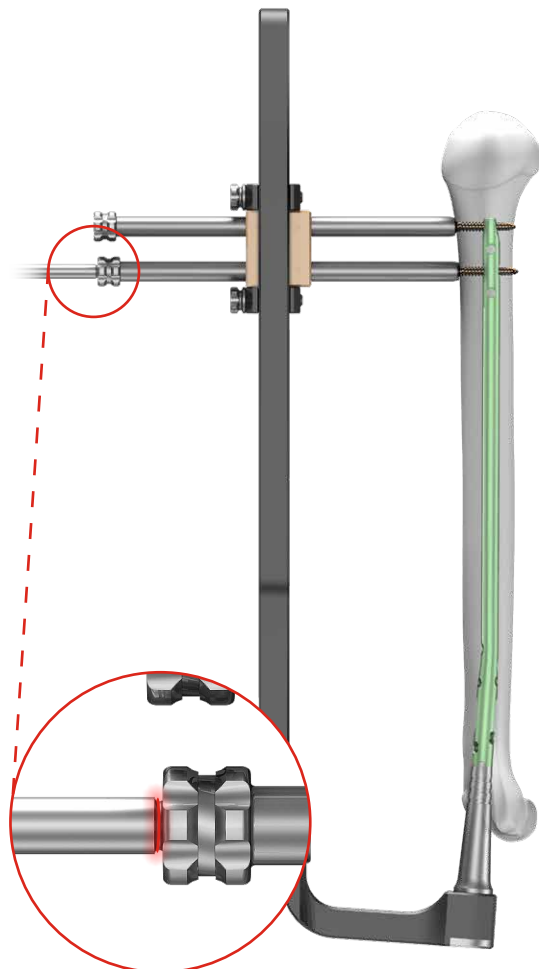
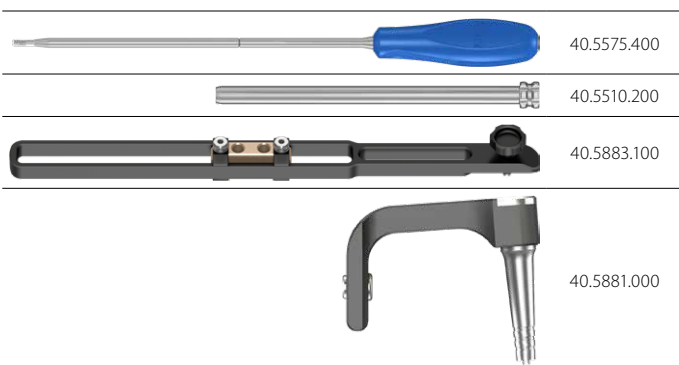

IV.3.8. Distal locking of the nail

IV.3.8.1. Fixation with compression

58 Mount the proximal targeter [40.5882.100] to the targeter arm [40.5881].



In fixation with compression, large and medial hole of the proximal targeter and the protective guide 18/7.0 [40.5035.100] shall be used.



40.5882.100



40.5881.000

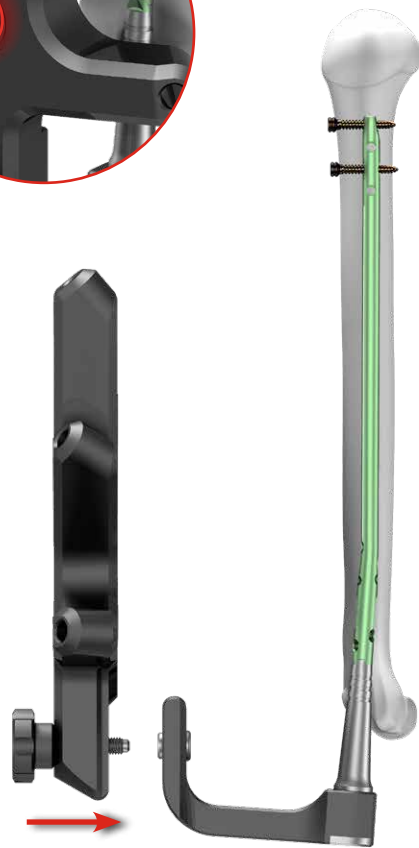

59 Insert the protective guide 18/7.0 [40.5035.100] with the trocar 6.5 [40.5534.100] into the proximal targeter [40.5882.100] hole. Mark on the skin the entry point for locking screw using the trocar and make adequate 4 cm incision through the soft tissues. Advance the protective guide and the trocar into prepared incision until the tip reaches the cortical bone. Using the trocar, mark the entry point for the drill.

Remove the trocar.

Leave the protective guide in the hole of the targeter.



40.5882.100



40.5035.100



40.5534.100

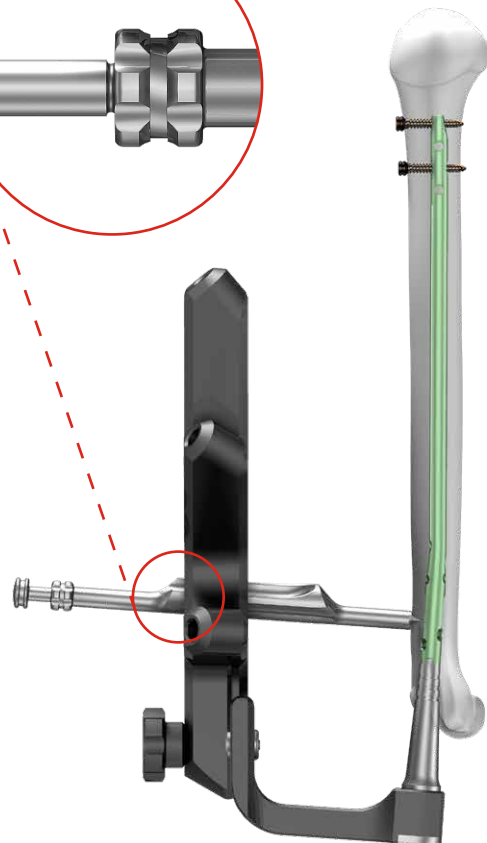
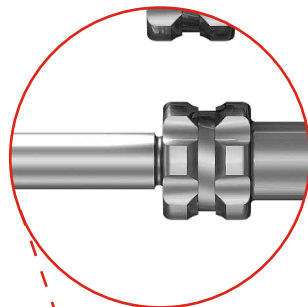

60 Insert the drill guide 7/3.5 **[40.5511.200]** into the protective guide 18/7.0 **[40.5035.100]**. Mount the drill 3.5/350 **[40.5339.002]** to the surgical drive and advance such system through the drill guide. Drill the hole for the locking screw under the X-Ray control. Read the length of the locking screw on the scale of the drill.



When measuring, the end of the protective guide should rest on the cortical bone.

Remove the drill and the drill guide.

Leave the protective guide **[40.5035.100]** in the hole of the targeter **[40.5882.100]**.

	40.5511.200
	40.5339.002

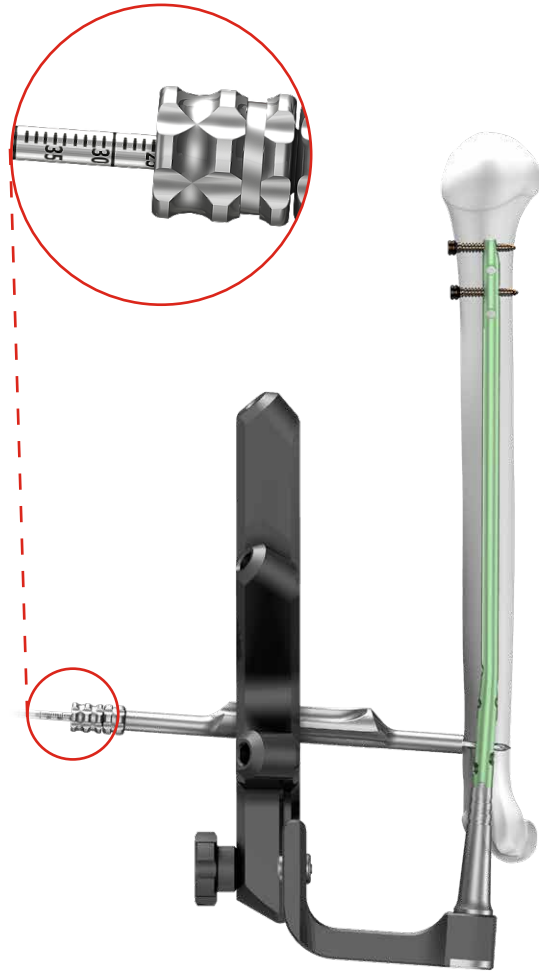

61 Insert the tip of the screwdriver T25 **[40.5575.400]** into the head of the determined locking screw. Then advance such system into the protective guide 18/7.0 **[40.5035.100]** and insert the locking screw into prepared hole until the head of the screw reaches the cortex bone (*the groove on the screwdriver shaft matches the edge of the protective guide*).

Remove the screwdriver and protective guide.

	40.5575.400
	40.5035.100

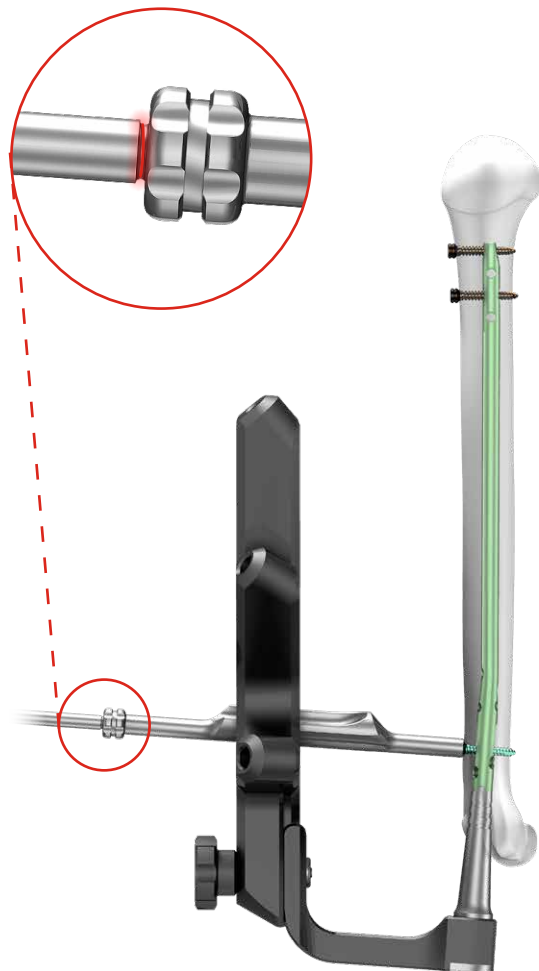

- 62 Insert the compression screw [40.5887] into the connecting screw [40.5884] to perform the compression of bone fragments.

	40.5884.000
	40.5887.000

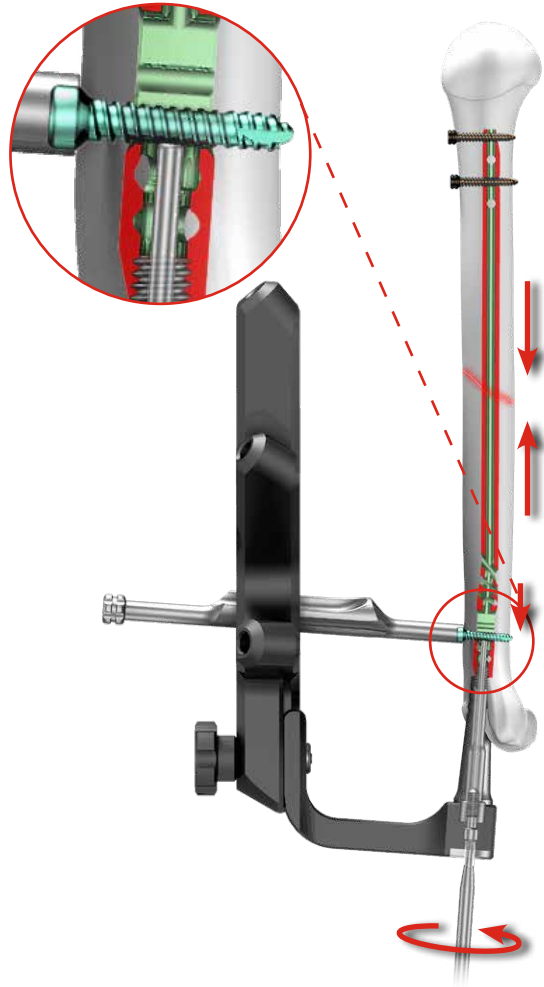

- 63 To preserve performed compression, insert at least one locking screw into the hole for static locking.

Remove the compression screw [40.5887].

	40.5887.000
---	-------------

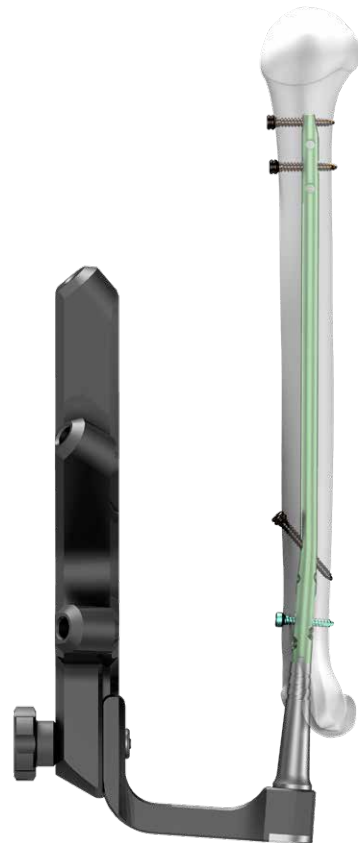

IV.3.8.2. Static fixation

Mount the proximal targeter [40.5882.100] on the targeter arm [40.5881].



In the static fixation, in the proximal part, use holes on the targeter arms and one oblique hole.



40.5882.100



40.5881.000



64 Insert the protective guide 9/7 [40.5510.200] with trocar 6.5 [40.5534.100] in selected distal hole of the proximal targeter [40.5882.100]. After marking the entry point of the locking screw on the skin, make 1.5 cm incision through the soft tissues. Advance the protective guide with the trocar into prepared incision until it reaches the cortical bone. Using the trocar, mark the entry point for the drill.

Remove the trocar.

Leave the protective guide in the hole of the targeter.

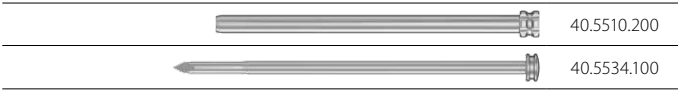
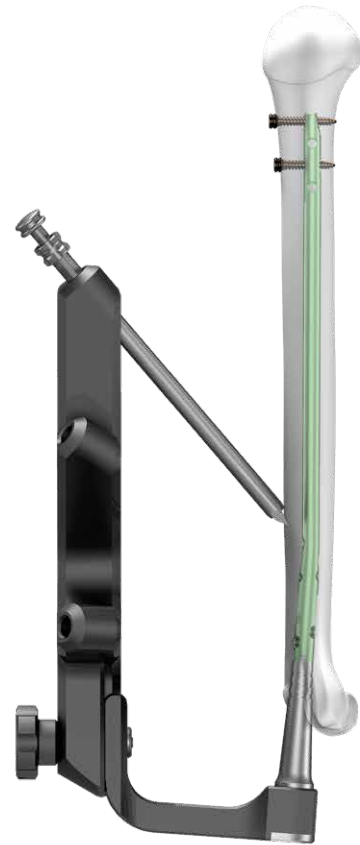

64a Optional

Insert cutter 7.0 [40.5897] in the left protective guide 9/7 [40.5510.200]. Manually turn the instrument to prepare the bone for drill insertion.

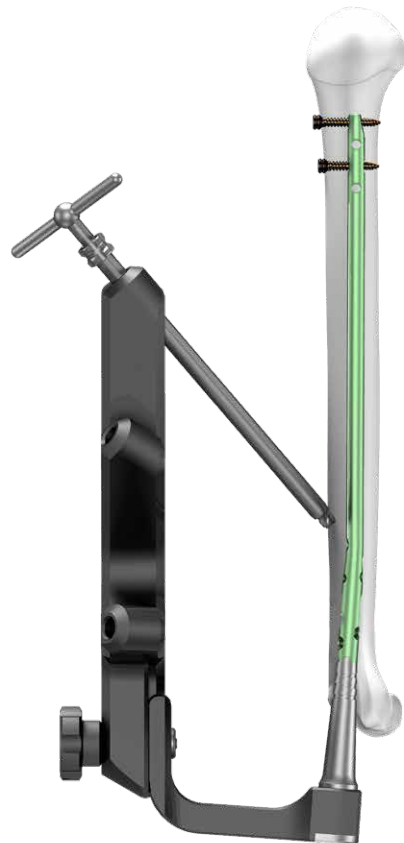
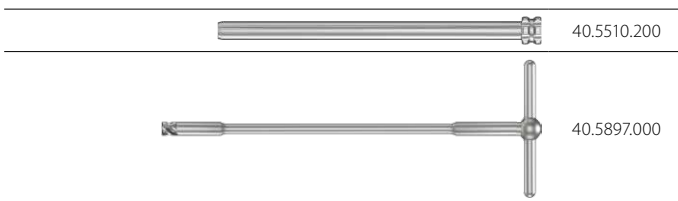

Remove the cutter 7.0

Leave protective guide in the targeter.



- 65** Drill the hole in the humeral bone for locking screw insertion.
 Insert the drill guide 7/3.5 mm **[40.5511.200]** into the protective guide 9/7 **[40.5510.200]**. Using the surgical drive and guiding the drill 3.5/350 **[40.5339.002]** in the drill guide, drill under X-Ray control the hole for locking screw. The scale on the drill indicates the length of locking element.

Remove the drill and drill guide.
 Leave the protective guide in the hole of the targeter.

	40.5510.200
	40.5511.200
	40.5339.002

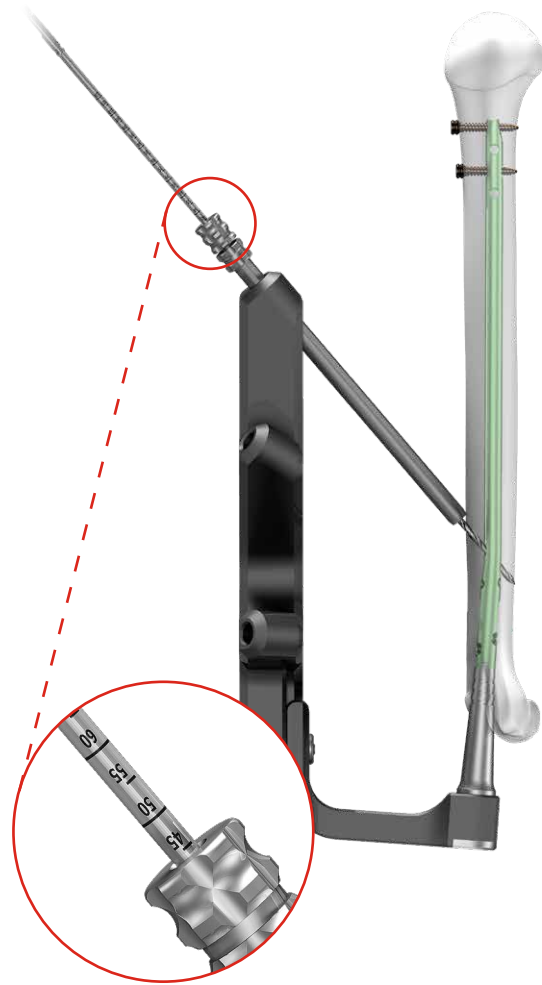



- 66** Insert the screw length measure **[40.5530.100]** through the protective guide **[40.5510.200]** into drilled hole until its tip reaches the end of the hole. Read the length of the locking screw on the B-D scale.



When measuring, the end of the protective guide should rest on the cortical bone.

Remove the screw length measure.
 Leave the protective guide in the hole of the targeter.

	40.5510.200
	40.5530.100

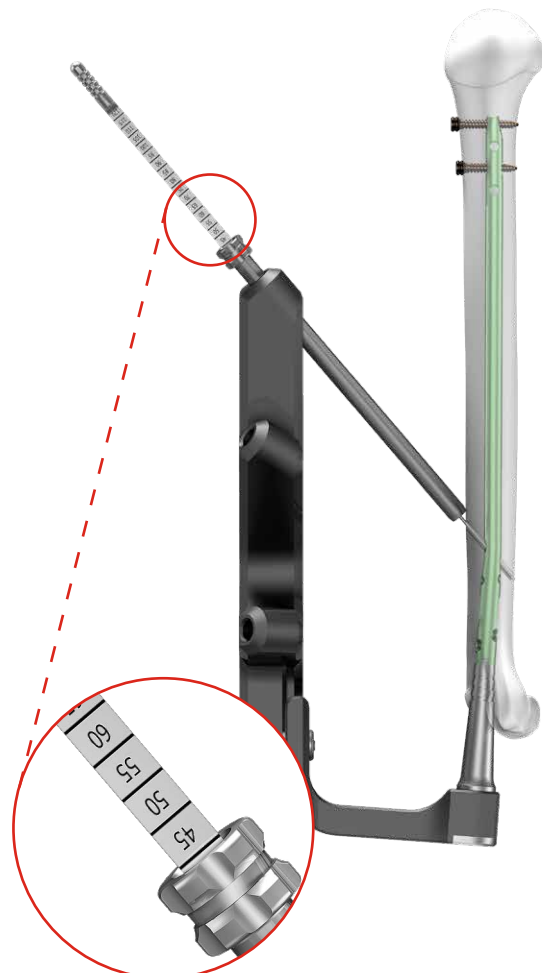

- 67 Insert the tip of the screwdriver T25 [40.5575.400] into the head of the determined locking screw. Then advance such system into the protective guide 9/7 [40.5510.200] and insert the locking screw into prepared hole until the head of the screw reaches the cortex bone (the groove on the screwdriver shaft matches the edge of the protective guide).

Remove the screwdriver and protective guide.
Remove proximal targeter.



If the surgeon decides to lock the nail in the proximal part with additional locking screws, then locking of the nail should be performed as shown in Chapter IV.3.8.2., selecting the next hole in the arm of proximal targeter.

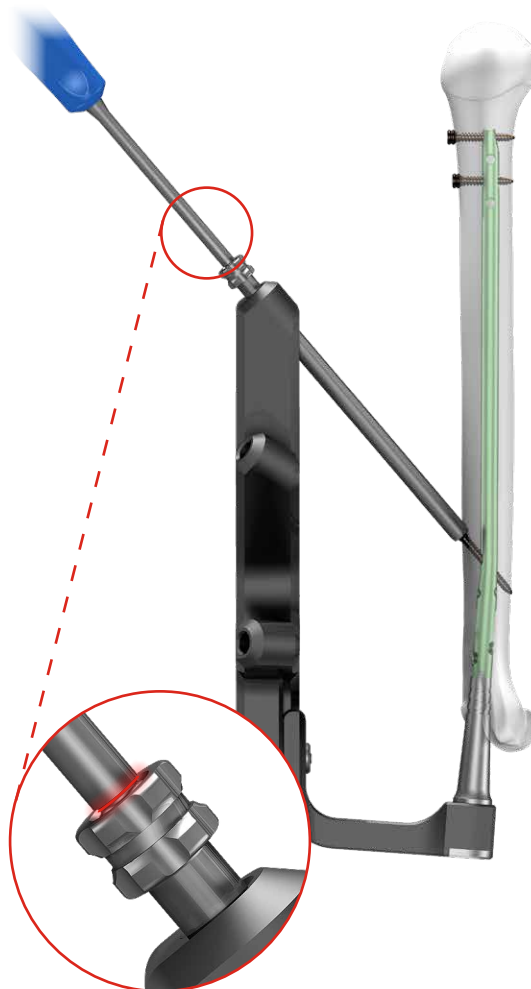
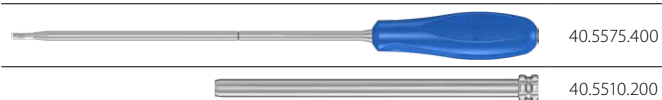

IV.4. TARGETER - NAIL DISASSEMBLY

- 68 Remove the targeter arm [40.5881] from the implanted nail by removing the connecting screw M6x1 spec. L-62 [40.5884] with the use of the wrench S8 [40.5304].

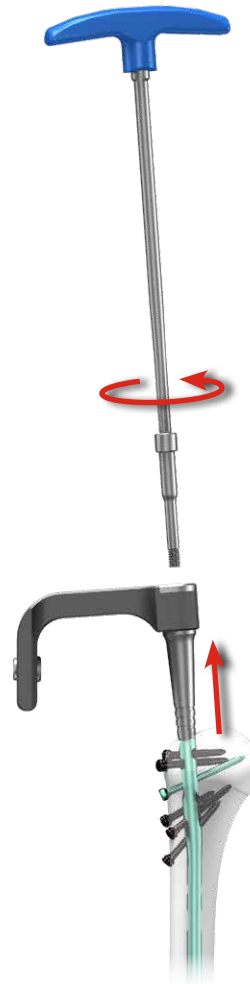
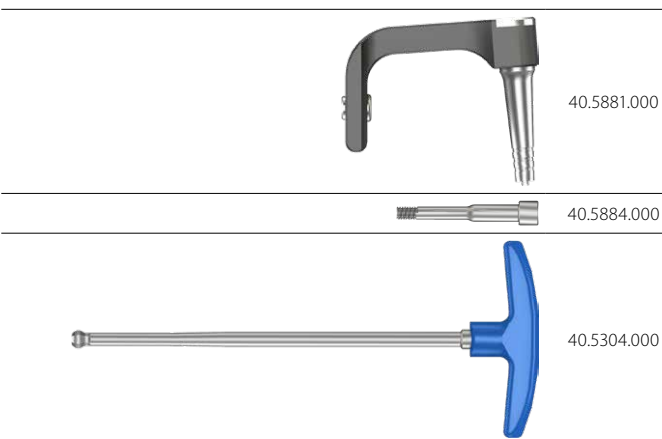

IV.5. INSERTION OF THE COMPRESSION SCREW OR END CAP

69 Insertion of compression screw: applies to fixation with compression.

Insert **CHARFIX2** Compression screw M6x1 [3.5162.004] (*implant*) into threaded nail shaft using the screwdriver T25 [40.5575.400].

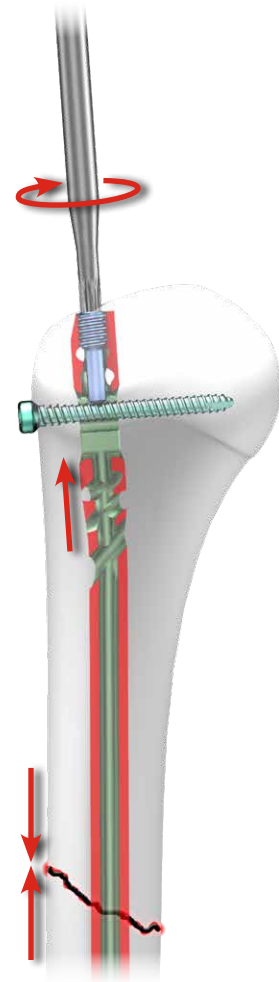

70 Insertion of the end cap: applies to dynamic and static fixation.

Insert **CHARFIX2** End cap M6 [3.5161.20x] into threaded nail shaft using the screwdriver T25 [40.5575.400] to protect the inner thread of the nail from tissue ingrowths.



IV.6. NAIL EXTRACTION

- 71 Remove the end cap or compression screw from the intramedullary nail shaft using the screwdriver T25 [40.5575.400].

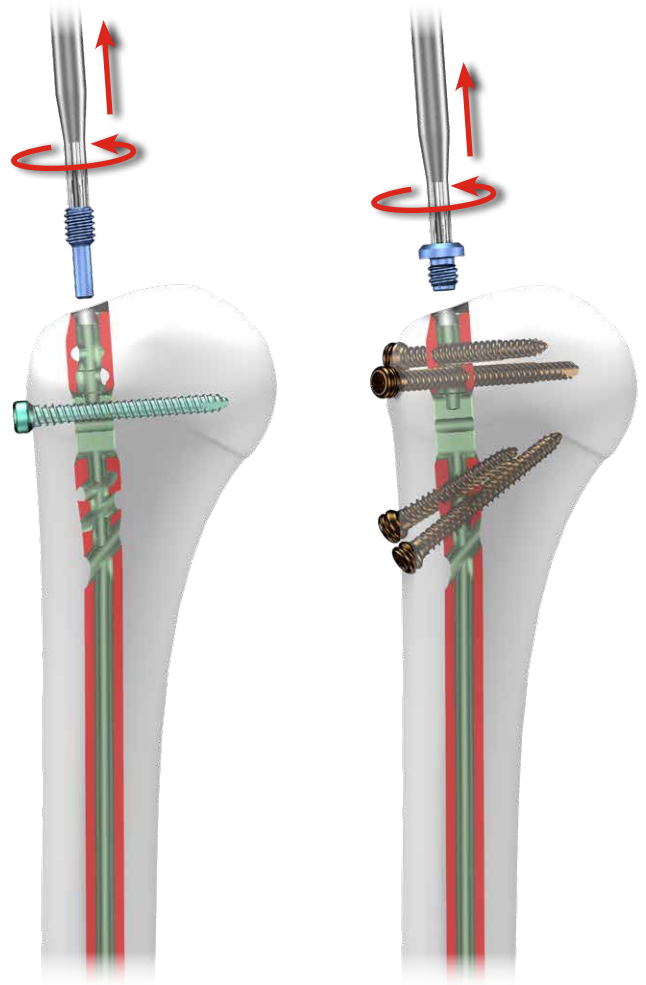

- 72 Remove all locking screws using the screwdriver T25 [40.5575.400].

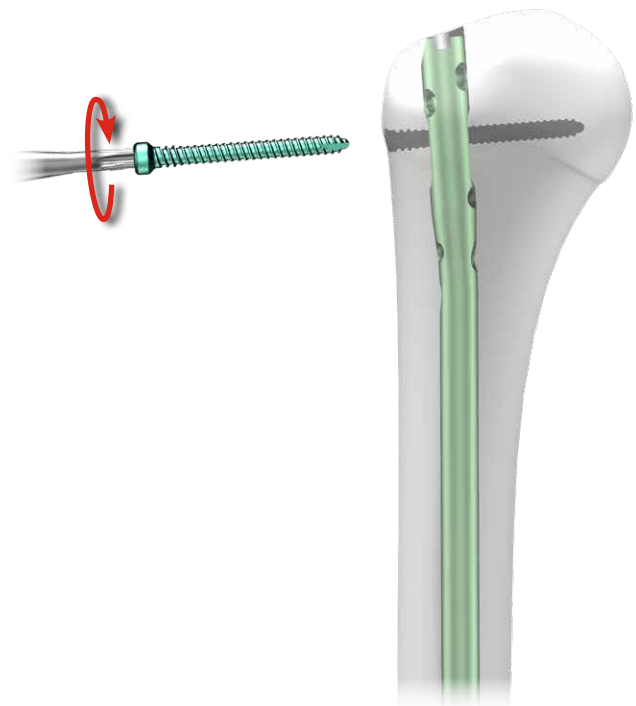

73 Attach the connector M6/M14 **[40.5888]** into the threaded shaft of the intramedullary nail. Mount the impactor-extractor **[40.5308]** to the connector and remove the nail from medullary canal using the mallet **[40.3667]**.

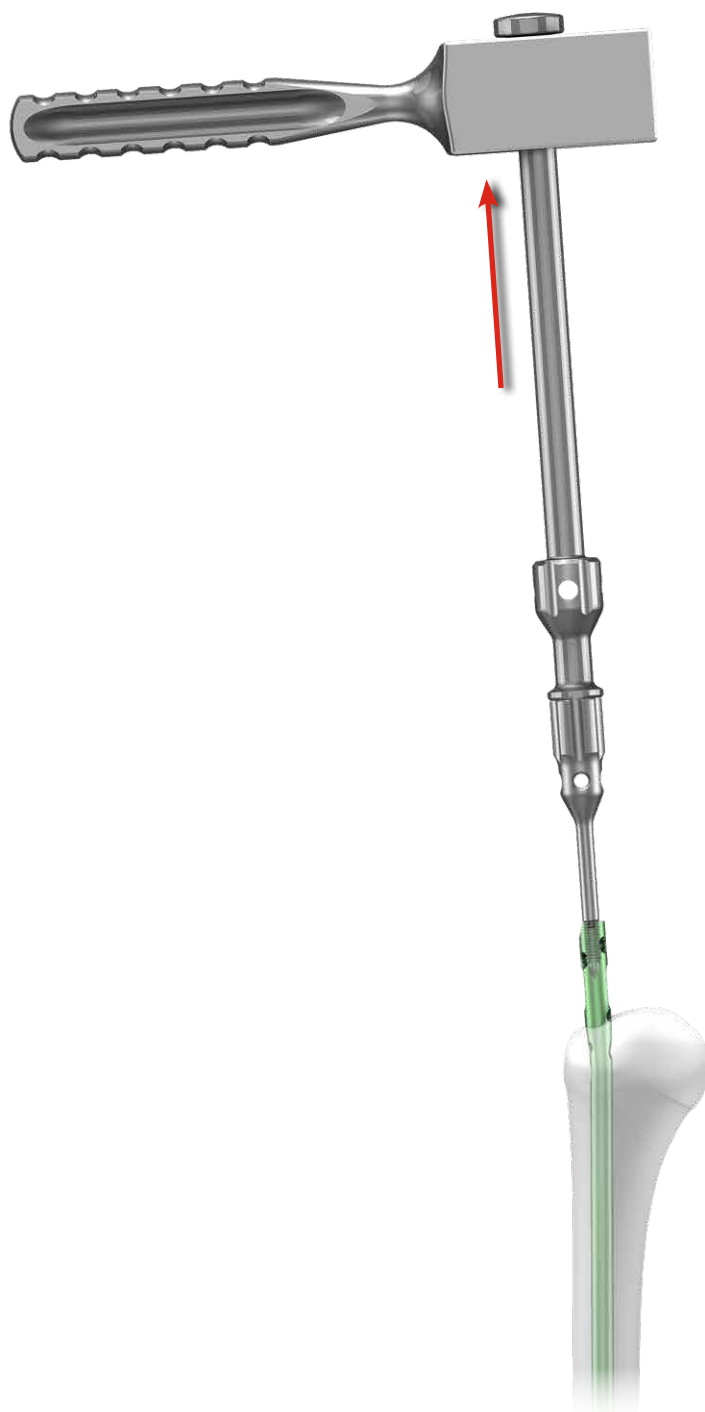
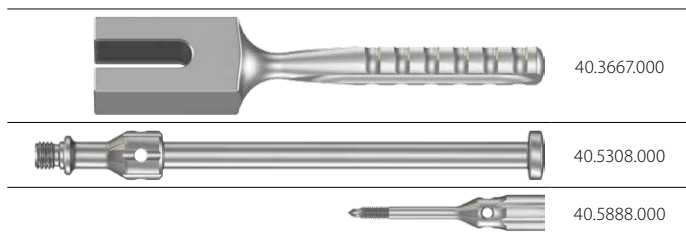

ChM sp. z o.o.

Lewickie 3b
16-061 Juchnowiec Kościelny
Poland

tel. +48 85 86 86 100

fax +48 85 86 86 101

chm@chm.eu

www.chm.eu



CE 0197